

/ ELEMENTS_

PROGRAMME OF
CUSTOMIZABLE PRODUCTS TO
BE CLAD AND INTEGRATED
SOLUTIONS FOR THE
BATHROOM ARCHITECTURE

/ ELEMENTS_

PROGRAMME OF
CUSTOMIZABLE PRODUCTS TO
BE CLAD AND INTEGRATED
SOLUTIONS FOR THE
BATHROOM ARCHITECTURE

*PROGRAMMA DI PRODOTTI PERSONALIZZABILI
E SOLUZIONI INTEGRATE PER L'ARCHITETTURA
DEL BAGNO.

/ ELEMENTS_

/ Elements è un progetto di grande respiro, ambizioso e innovativo, in linea con la storia aziendale da sempre orientata a creare prodotti in grado di proporsi con un alto livello di integrazione all'interno degli spazi abitativi. Alla base del programma è l'uso di un linguaggio espressivo comune al mondo dell'architettura d'interni in cui le relazioni fra i piani orizzontali e verticali, i pieni e vuoti dei volumi, i materiali e le finiture dialogano in uno stretto e continuo rapporto finalizzato a determinare lo spazio architettonico. Frutto di intuizione, sperimentazione ed esperienza tecnica / Elements propone per ogni area funzionale del bagno un abaco ampio e trasversale di prodotti da rivestire. Il comune denominatore è il TechnoPVC, materiale in continuo sviluppo tecnologico ed in linea con i valori di sostenibilità ambientale, le cui peculiarità permettono di raggiungere i massimi livelli prestazionali.

/ Elements is a wide, ambitious and innovative project in line with the company's history, which has always aimed at creating products capable of offering a high level of integration within living spaces. Underlying all the products in the programme is the use of an expressive language common to the world of interior architecture, in which the relationships between horizontal and vertical planes, the full and empty volumes, materials and finishes are in a close and continuous relationship, aimed at determining architectural space. As result of intuition, experimentation and technical experience, / Elements suggests a wide and transversal range of products to be clad for each functional area of the bathroom. The common denominator is TechnoPVC, a material in continuous technological development and in line with the values of environmental sustainability, whose peculiarities enables to achieve the highest levels of performance.

TECHNOPVC®

/ Elements assume come materiale di riferimento il TechnoPVC, tecnopolimero in grandissima evoluzione tecnica e che, grazie agli sviluppi tecnologici degli ultimi anni, ha raggiunto alti livelli di sostenibilità ambientale. Impermeabilità, leggerezza, eccezionale lavorabilità e finitura superficiale che ne consente una rivestibilità diretta anche con resine cementizie, sono caratteristiche di fondamentale importanza del materiale. E' la saldabilità la sua prerogativa essenziale che permette in fase d'opera l'eliminazione di ogni altro elemento impermeabilizzante aggiuntivo, garantendo livelli di sicurezza superiori. Il costante approfondimento tecnico ha permesso inoltre lo sviluppo di uno specifico know-how sia dei singoli prodotti, sia nell'integrazione di dettagli costruttivi per il mondo delle partizioni di interni.

/ Elements takes TechnoPVC as its reference material. TechnoPVC is a technopolymer which has undergone great technical evolution and, thanks to technological developments in recent years, has achieved high levels of environmental sustainability. Impermeability, lightness, exceptional workability and a smooth surface that allows the products to be directly clad even with cement resins, are key features of the material. Welding is its essential benefit. This prevents the use of any other additional waterproofing component during the construction phase, ensuring higher safety levels. Constant in-depth technical research has also enabled the development of specific know-how both as individual products and in the integration of construction details for the world of interior partitions.

LEGENDA

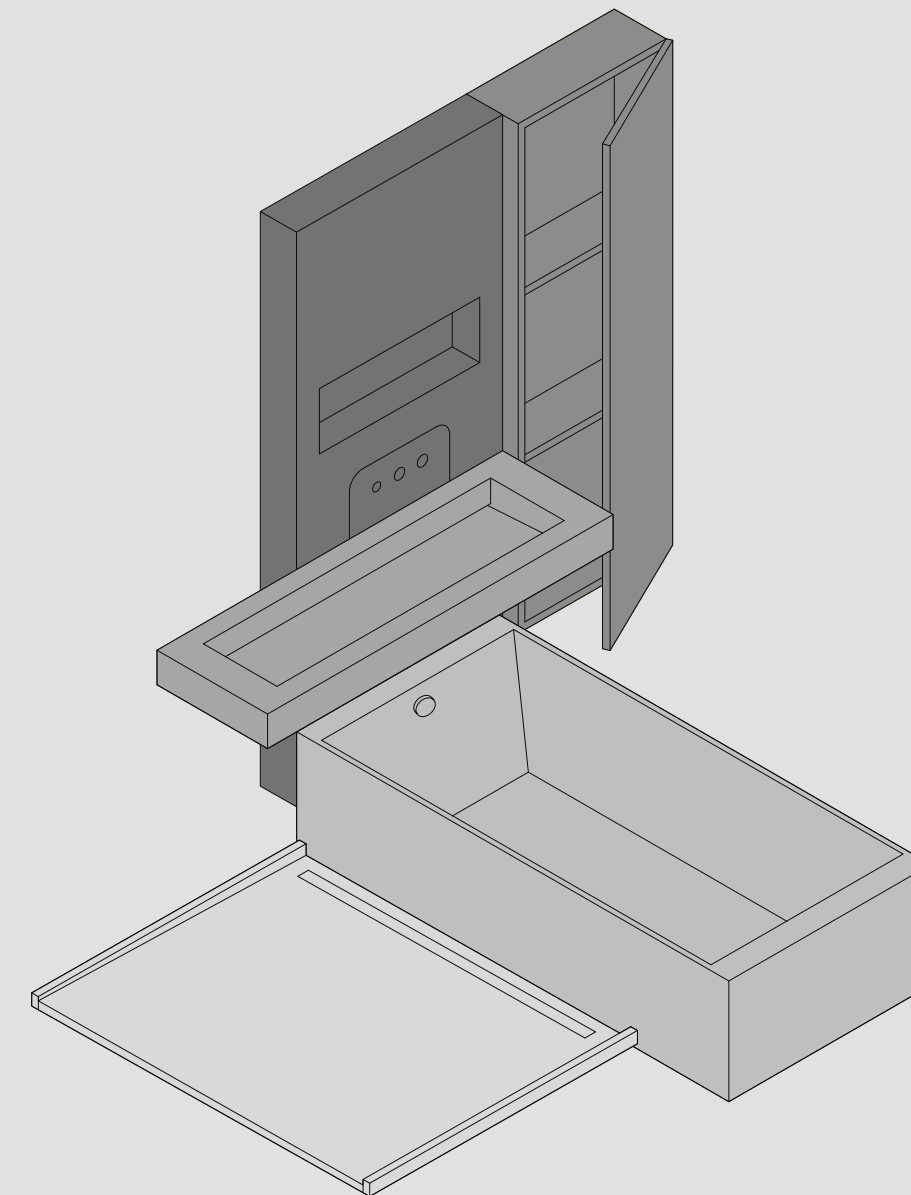

- / ELEMENTS_BATHTUBS
 - R-LINE
 - Q-LINE
- / ELEMENTS_TECHNOWALL
 - WASHBASIN
 - BATHTUB
 - SANITARY WARE
 - FITTINGS
- / ELEMENTS_SHOWER TRAYS
 - UNICO
 - INSIDE
 - BASIC
 - LINK
- / ELEMENTS_WASHBASIN AREA
 - MAXI
 - BRIDGE
 - MODULO T
 - SLASH
 - PURO
- / ELEMENTS_VANITIES
 - MAXI + CABINET
 - BRIDGE + CABINET
 - GRAPHIC - DOMINO
 - PUNTO.ZERO
 - BARCODE

**LEGGERO**

Le lastre combinano un'anima in PVC espanso, dal peso eccezionalmente leggero, a una superficie solida e compatta;

LIGHTWEIGHT

PVC slabs are equipped with an inner part in expanded polystyrene, which is very light, and an external surface extremely hard and compact;

**IMPERMEABILE**

Impenetrabile dai liquidi, gas e dai vapori. Struttura a cellule chiuse;

IMPERMEABILITY

PVC is waterproof, resistant to gases and steams/vapours. Closed cells structure;

**RESISTENTE**

Manufatti in PVC risultano solidi con un'ottima resistenza agli urti;

STRENGTH

PVC-based products are chock resistant;

**DUREVOLE**

I manufatti in PVC sono eccezionalmente durevoli, con una vita variabile dai 15 ai 100 anni nella maggioranza delle applicazioni;

LONG LASTING

PVC products are long lasting. Their useful life spans between 15 and 100 years according to the item and application;

**SICURO**

Il TechnoPVC è auto estinguente e non contribuisce alla propagazione del fuoco;

SAFE

TechnoPVC is self-extinguishing and does not contribute to the spread of fire;

**TERMOISOLANTE**

Il PVC è molto performante dal punto di vista dell'isolamento termico;

THERMAL INSULATION

PVC is well performing where thermal insulation is needed;

**SALDABILE**

Le lastre sono saldabili, questo consente di realizzare manufatti monolitici;

WELDING

PVC can be welded, so that monolithic blocks in PVC can be produced;

**IGIENICO**

Il PVC è stabile e inerte, caratteristica fondamentale per tutti gli usi in cui l'igiene è una priorità;

HYGIENE

PVC is stable and inert. It is a crucial material where hygiene is a priority;

STRUTTURALE

La saldatura di lastre a forte spessore permette di realizzare prodotti strutturalmente solidi e compatti, forniti in pezzo unico o da saldare in opera.

STRUCTURAL

Welding thick slabs leads to the production of structurally solid and compact products, supplied in one piece or to be welded on site.

**COMPOSITO**

In accoppiamento con il polistirene si ottengono compositi solidi con ottime qualità prestazionali e in particolare di isolamento termico e acustico.

COMPOSITE

When combined with polystyrene, solid composites are obtained with high performance from the thermal to the acoustic insulation point of view.

**SPESSORI**

Lo spessore delle lastre impiegate per le lavorazioni varia da 6 a 30 mm in in base al prodotto, alla funzione a cui è preposto, alle esigenze strutturali, e al tipo di materiale di rivestimento

THICKNESS

The thickness of the slabs used varies from 6 to 30 mm depending on the product, its intended function, the structural requirements and the type of cladding

**SALDABILE**

Il processo di saldatura è una caratteristica fondamentale del Technopvc in quanto consente di ottenere prodotti con il massimo grado di sicurezza di tenuta ed efficienza idraulica.

WELDING

Welding is a key feature of Technopvc as it leads to products with the highest degree of sealing security and hydraulic efficiency



CLADDINGS

I prodotti si contraddistinguono per l'aspetto monolitico e la superficie liscia e planare, soluzione ideale sia per i rivestimenti continui come cemento e resine sia per i rivestimenti tradizionali: ceramiche, mosaici e materiali in lastra quali gres, marmi e agglomerati. La rapidità di installazione dei prodotti e l'immediatezza alla conseguente fase di rivestimento è difficilmente replicabile con i sistemi costruttivi classici; allo stesso modo garantisce qualità formale e controllo certo dei costi di gestione.

The products are monoliths with a smooth, flat and highly resistant surface, suitable for resins and cements but also for traditional cladding, such as ceramic, mosaics, tiles, marbles and composite materials. Their easy installation and subsequent quick cladding are the distinctive features of the range, which can't be easily achieved with the standard construction systems. At the same time it grants quality and cost saving.



RESINA

Rivestimenti a superficie continua e a basso spessore aderiscono perfettamente al TechnoPVC previa stesura di solo primer.

RESIN

Continuous surface and low thickness coatings adhere perfectly to TechnoPVC, directly after primer application.



CERAMICA

Per tutti i tipi di rivestimento ceramico, modulare o in lastra l'incollaggio su TechnoPVC ne aumenta in modo sensibile le prestazioni in particolare per bassi spessori.

CERAMIC TILES

All types of ceramic, modular or slab cladding increase their performance when they are glued to TechnoPVC, especially for low thicknesses.



MATERIALI LAPIDEI

Qualsiasi materiale lapideo può essere impiegato su TechnoPVC, compresi i materiali fragili e a spessore ridotto.

MARBLE

Any stone material can be used on TechnoPVC, including fragile and thin materials.



MOSAICO

La customizzazione dei prodotti /Elements consente l'adattamento dimensionale alle tessere mosaicali, oltre alla perfetta adesione al supporto.

MOSAIC

The customization of /Elements products allows dimensional adaptation to the mosaic tiles as well as a perfect gluing on the structure.

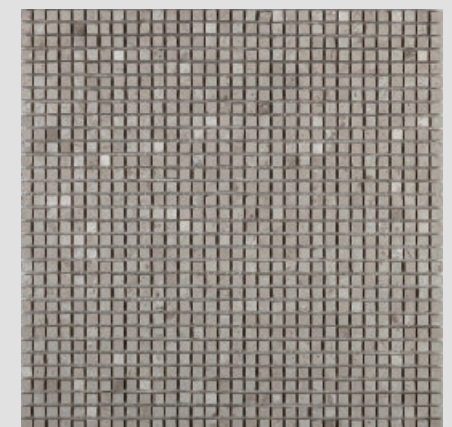

BATHROOM SUGGESTIONS



BATHROOM ONE

CONTEMPORANEO

Uno stile sempre più lifestyle per un bagno dall'aspetto scultoreo e contemporaneo.

CONTEMPORARY

An increasingly lifestyle approach for a bathroom with a sculptural and contemporary look.



BATHROOM TWO

SENZA TEMPO

Un bagno senza tempo, uno spazio ricercato e minimalista dal disegno geometrico deciso.

TIMELESS

A timeless bathroom, a refined and minimalist space with a strong geometric design.



BATHROOM THREE

UN NUOVO CONCETTO

Una parete attrezzata integra perfettamente sistemi funzionali e arredi: un concetto evoluto per una nuova architettura del bagno.

A NEW CONCEPT

A technical wall perfectly integrates furnishings and functional systems. This is an advanced concept for a new bathroom architecture.

BATHROOM ONE

La vasca centrale è il fulcro dell'organizzazione spaziale di questa sala da bagno. La sua centralità e la massa scultorea in continuum con il pavimento creano un effetto di grande forza e carattere. Sullo sfondo, filtrati da Trama, nuovo divisorio metallico, fanno da contrappunto le geometrie grafiche del lavabo Bridge in resina cemento, abbinato ai mobili sospesi del programma.

The central tub is the heart of the spatial organization of this bathroom. Its centrality and the sculptural mass in continuum with the floor create an effect of great strength and character. In the background, filtered by Trama, the new metal partition, act as a counterpoint the graphic geometries of the washbasin Bridge in concrete resin, combined with suspended furniture of the program.

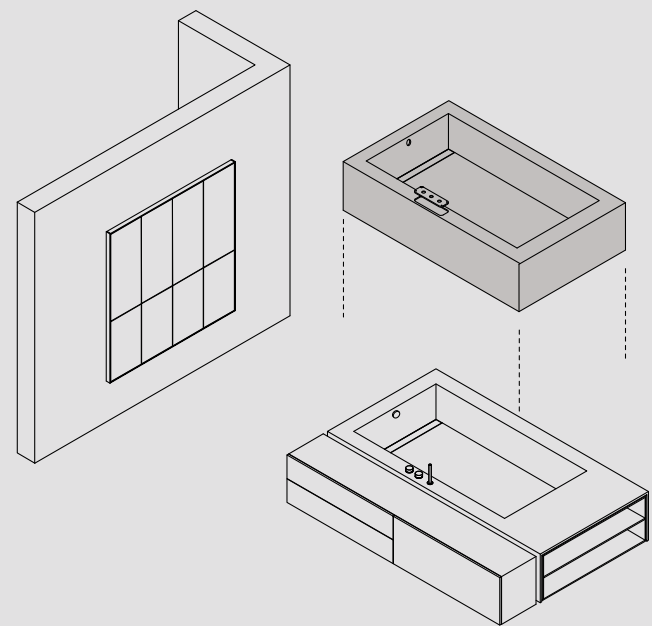



Le vasche Line in TechnoPVC, quadre e rettangole, sono disponibili con scarico lineare o centrale e sono accessoriabili con ribassi, gradini interni e schienali strutturali o in legno.

Line bathtubs in TechnoPVC, square and rectangular, are available with linear or central drain and can be equipped with lowerings, internal steps and structural or wooden backrests.

< Contenitori e vani a giorno, accostati o integrati, oltre a creare equilibrate contrapposizioni di pieni e vuoti con la vasca stessa, permettono di ottimizzare gli spazi di contenimento.

< Storage units and open racks, combined or integrated, create balanced contrasts of full and empty spaces with the tub itself optimizing the storage areas.

Bridge è un lavabo dal segno deciso, un richiamo all'idea di blocco scavato. Il leggero scostamento da parete retroilluminato mette in evidenza la sua tridimensionalità e una straordinaria leggerezza visiva, accentuata dalle basi sospese laccate in tono con la finitura cemento del lavabo.

Bridge is a washbasin with a decisive sign, a reference to the idea of an excavated block. The slight and backlit distance from the wall highlights its three-dimensionality and an extraordinary visual lightness, stressed by the lacquered floating vanities in tone with the cement finishing of the washbasin.

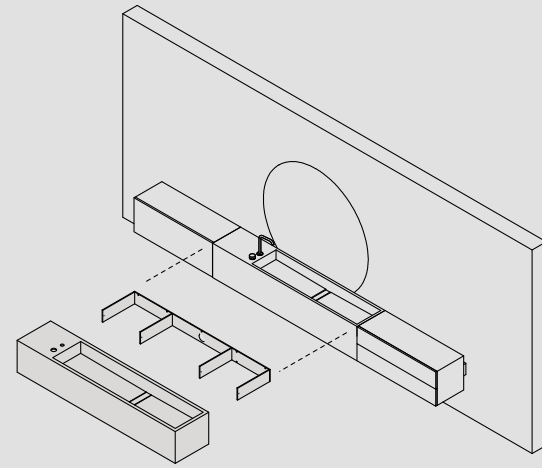

LINE _ R BATHTUB

NATURAL GRAY
MARBLE

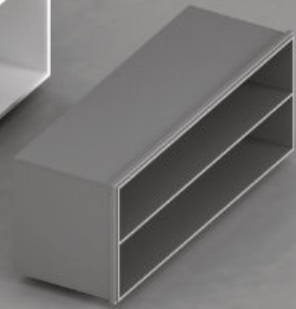
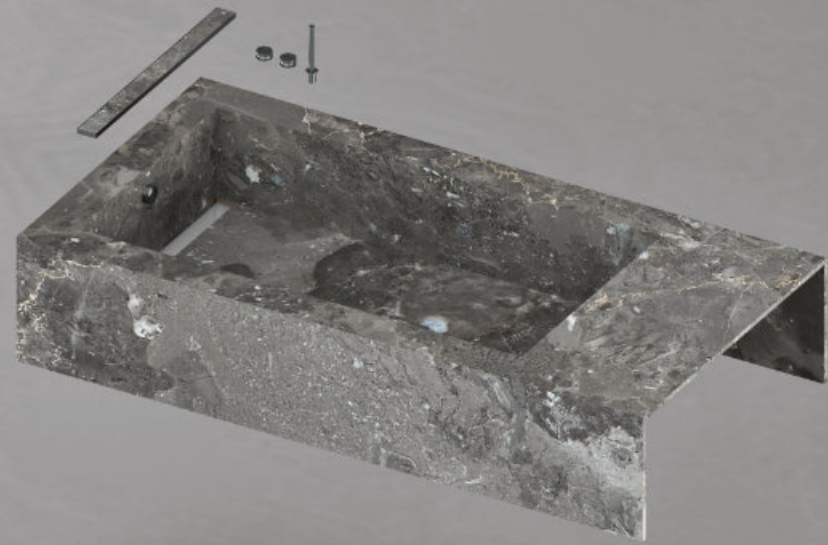

GRAPHIC CABINET
NOCE CANALETTO

GRAY LACQUERED
CABINET

BRIDGE WASHBASIN

CEMENT

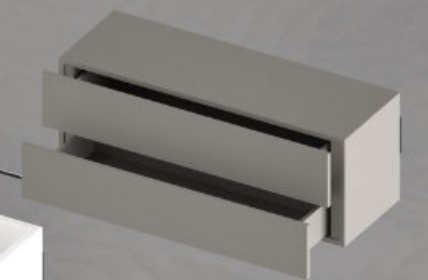
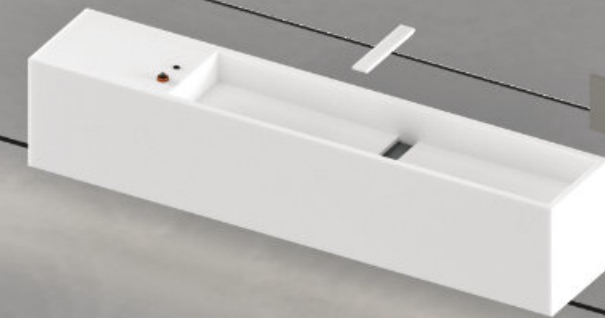

DOVE GRAY
LACQUERED CABINET

LIGHT

BATHROOM TWO

Un progetto dai chiari segni architettonici spesso sottende soluzioni tecniche complesse. Ne è esempio questa composizione in cui vasca e doccia in marmo dialogano in un gioco reciproco di vuoti e pieni e di chiaroscuri. La vasca è semi-incassata nel pavimento e con un lato a filo muro. L'area doccia è incentrata sul setto Technowall a tutta altezza, che definisce lo spazio insieme al piatto doccia con scarico lineare Unico e alla chiusura in vetro fumé con anta a bilico.

A project with clear architectural signs often implies complex technical solutions. An example is this composition, in which bathtub and shower in marble dialogue in an interplay of full and empty spaces, and lights and shades. The tub is semi-recessed in the floor and with one side flush with the wall. The shower area is centred on the full-height Technowall screen, which defines the space together with the shower tray Unico with linear drain and the smoked glass enclosure with pivoting door.

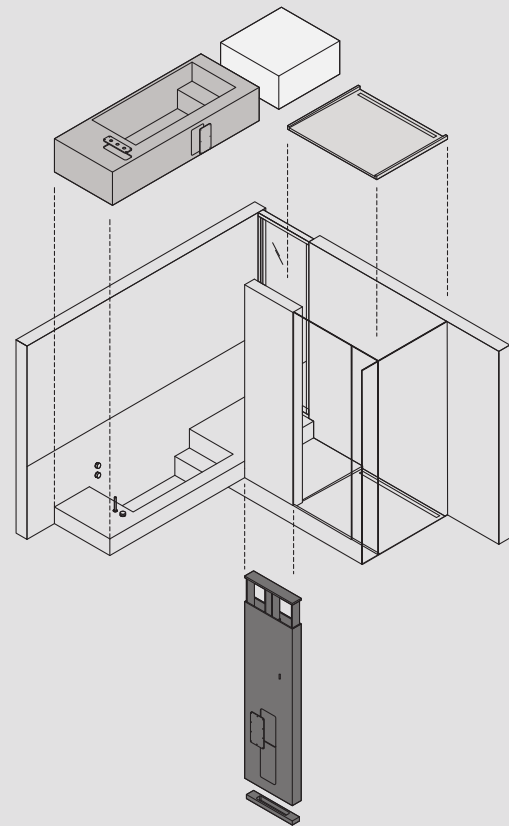



La vasca con un lato a filo muro annulla il concetto oramai scontato di prodotto estetico-funzionale per trasmettere invece suggestioni emotive che rimandano agli spazi essenziali e minimalisti della cultura zen e ai suoi paradossi di vuoto e pieno.

The bathtub with one side flush with the wall overcomes the mere concept of aesthetic-functional product and conveys emotional suggestions of essential and minimalist spaces of the Zen culture and its paradoxes of empty and full.

> La tecnica costruttiva del piatto doccia Unico con scarico lineare integrato, caratterizzato da bordi e rialzi perimetrali pre-saldati, risolve in via definitiva le problematiche di sicurezza idraulica.

> The construction technique of the Unico shower tray with integrated linear drain, characterized by pre-welded borders and perimeter rises, definitively solves the issue of watertightness.

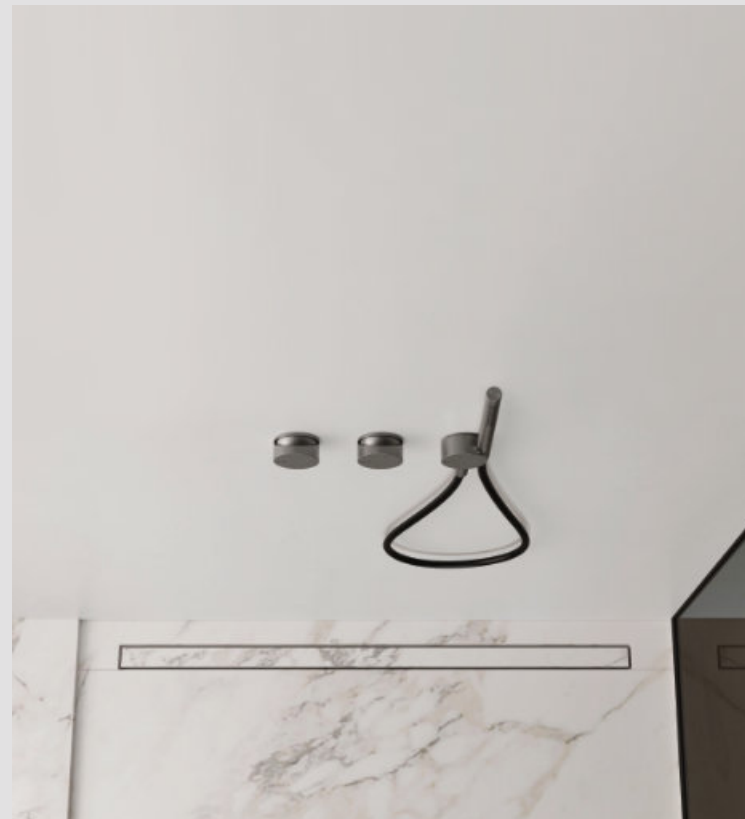

Vasche e sistemi doccia sono declinabili in una molteplicità di soluzioni che permettono la composizione degli elementi secondo l'esigenza progettuale.

Bathtubs and shower systems can be declined in a variety of solutions that allow the composition of elements according to the design requirement.



Una raffinata geometria di campiture verticali e orizzontali disegnano la parete con il lavabo rivestito, caratterizzato dalla coplanarità degli elementi e da un equilibrato gioco di materiali e di toni. Il lavabo Maxi con scarico lineare nascosto e cassetto in rovere, è parte integrante del Technowall strutturale a filo parete.

A refined geometry of vertical and horizontal backgrounds draw the wall with the sink, characterized by the coplanarity of the different units and by a balance of materials and tones. The Maxi washbasin with hidden linear drain and drawer in oak is an integral part of the structural Technowall flush with the wall.

> Una sequenza di ante modulari a filo muro celano, come uno scrigno, una teoria di specchi in movimento e vani di contenimento. L'inaspettata apertura dell'anta a 180° stupisce per l'originalità e il dettaglio tecnico della cerniera.

> A sequence of modular doors flush with the wall hide, like a casket, a series of moving mirrors and storage modules. The unexpected 180° opening of the door amazes for the originality and technical detail of the hinge.

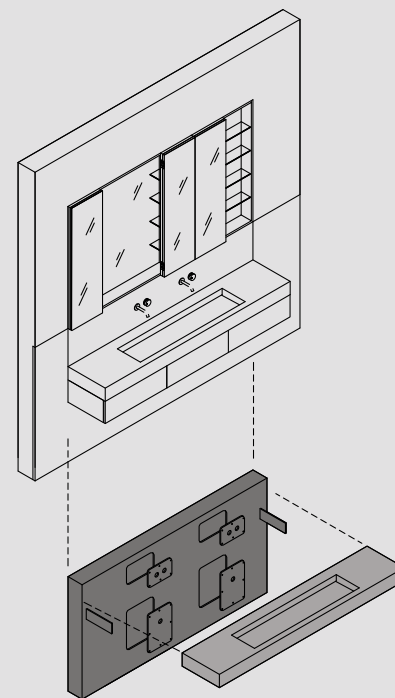

LINE _ Q
TECHNOWALL SHOWER

NATURAL MATERIAL



ALUMINUM

GLASS

PUNTO.ZERO
TECHNOWALL WASHBASIN

CARRARA MARBLE



NATURAL OAK

MIRROR

BATHROOM THREE

Una parete attrezzata che integra una grande doccia dalle linee essenziali, il setto dei sanitari e una serie di mobili complanari alla doccia stessa, sono lo sfondo ideale per il mobile da terra Modulo 45 con lavabo in gres ceramico. I mobili a colonna e pensili fanno parte della nuova proposta / Elements dedicata al contenimento: una proposta flessibile per dimensioni, tipologia e finiture in grado di offrire soluzioni compositive esclusive.

A technical wall that integrates a large shower with clean lines, the screen of sanitary ware and a series of furniture pieces flush with the shower itself, are the ideal background for the Modulo 45 floor cabinet with stoneware washbasin. Column units and cupboards are part of the new Elements proposal dedicated to storage. One flexible proposal for dimensions, typology and finishes in order to offer exclusive compositional solutions



Il sistema doccia è realizzato interamente in TechnoPVC rivestito in lastre di gres sottile in abbinamento a una superficie continua in resina bianca. Prevede l'integrazione di piatto con scarico a parete Inside, setto parete Technowall e ciellino complanare completo di soffione, profili e cerniere per il box.

The shower system is entirely made in TechnoPVC clad in thin stoneware slabs in combination with a continuous surface in white resin. It includes the integration of Inside tray with wall drain, Technowall partition and coplanar ceiling complete with shower head, profiles and hinges for the shower enclosure.

> Per ricercatezza estetica e funzionale Inside è un chiaro esempio della grande proposta progettuale del programma completo / Elements. Un piatto con scarico lineare a parete progettato per rivestimenti da 3 a 35 mm di spessore. Inside è integrabile sia con le pareti Technowall sia con le sedute di serie da pavimento.

> Based on its aesthetic and functional refinement Inside is a clear example of the great design proposal of the complete program / Elements. A shower tray with wall linear drain designed for 3 to 35mm thick cladding. It can be integrated with both Technowall and the standard floor seats.

Il grande lavabo Maxi con scarico lineare nascosto è rivestito con una lastra sottile di gres ceramico inserito nel mobile a terra Modulo45.

The large Maxi washbasin with hidden linear drain is clad with a thin slab of ceramic stoneware inserted into the floorstanding cabinet Modulo 45.

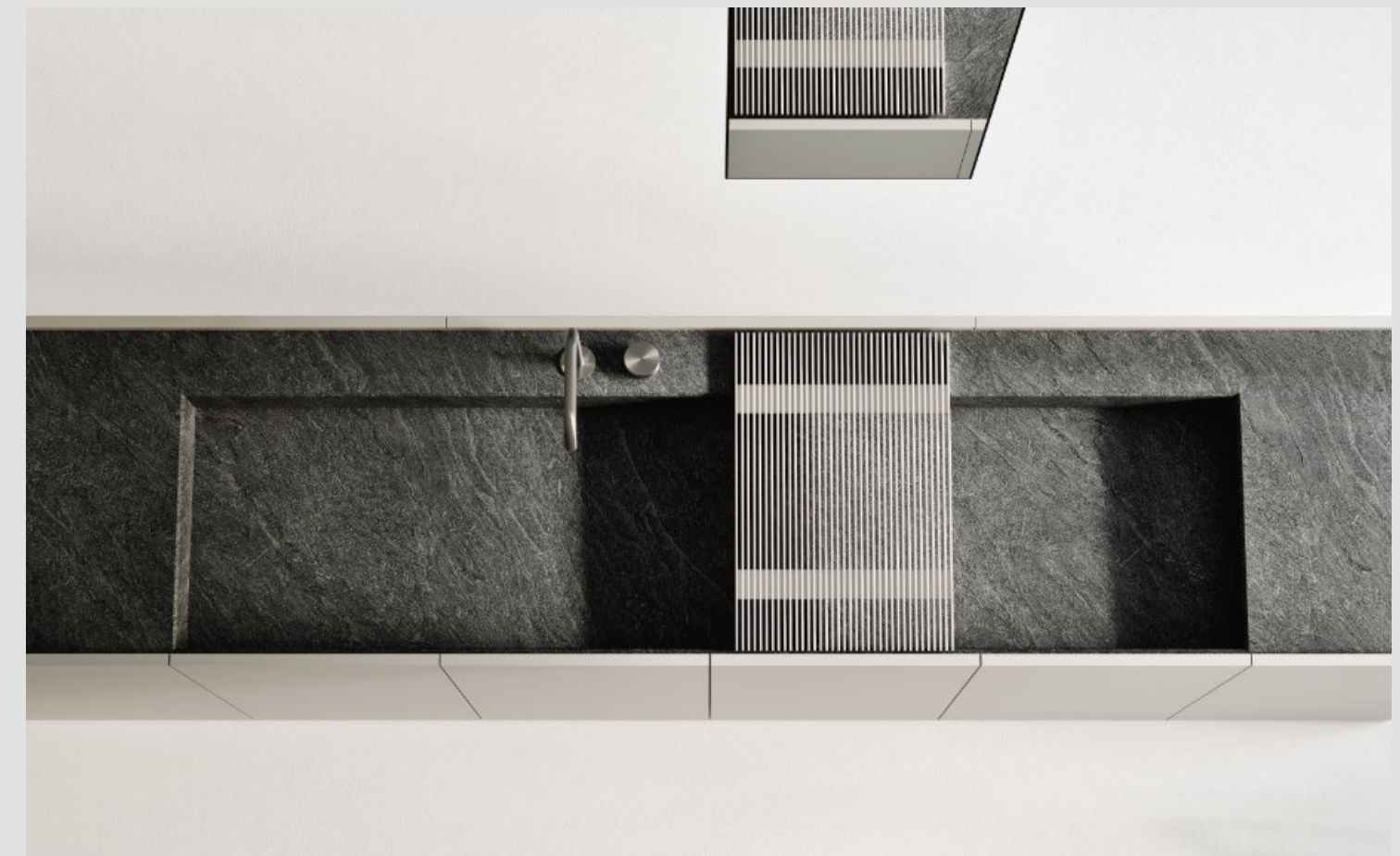

Caratteristiche e performance del TechnoPVC consentono di realizzare sistemi doccia di grande valenza estetica, completamente svincolati dalle tradizionali problematiche tecniche e costruttive. Un sistema in cui piatto doccia Inside, setto parete Technowall e ciellino Sky diventano un solo elemento personalizzabile con un'ampia gamma di accessori.

The peculiar characteristics and performance of TechnoPVC allow the creation of shower systems of great aesthetic value, completely independent from traditional technical and construction problems. A system in which the Inside shower tray, the Technowall partition wall and Sky ceiling become one single unit customizable with a wide range of accessories.

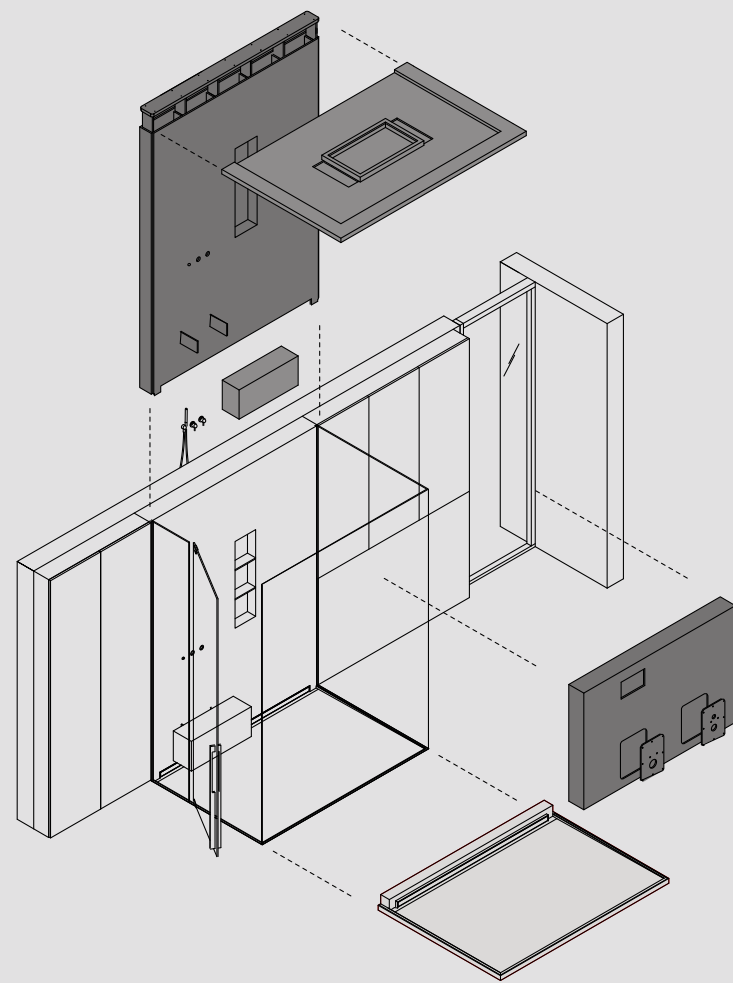

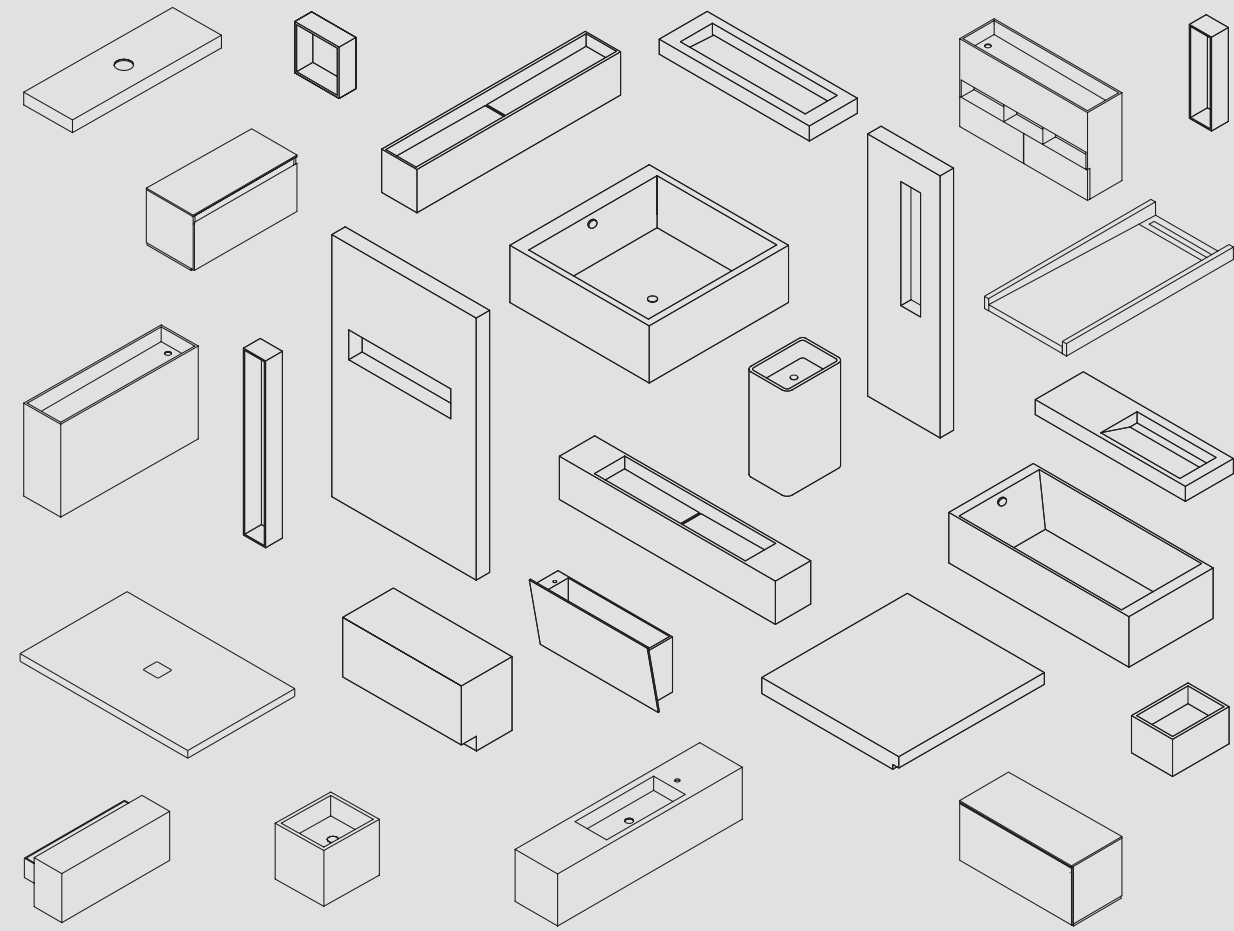
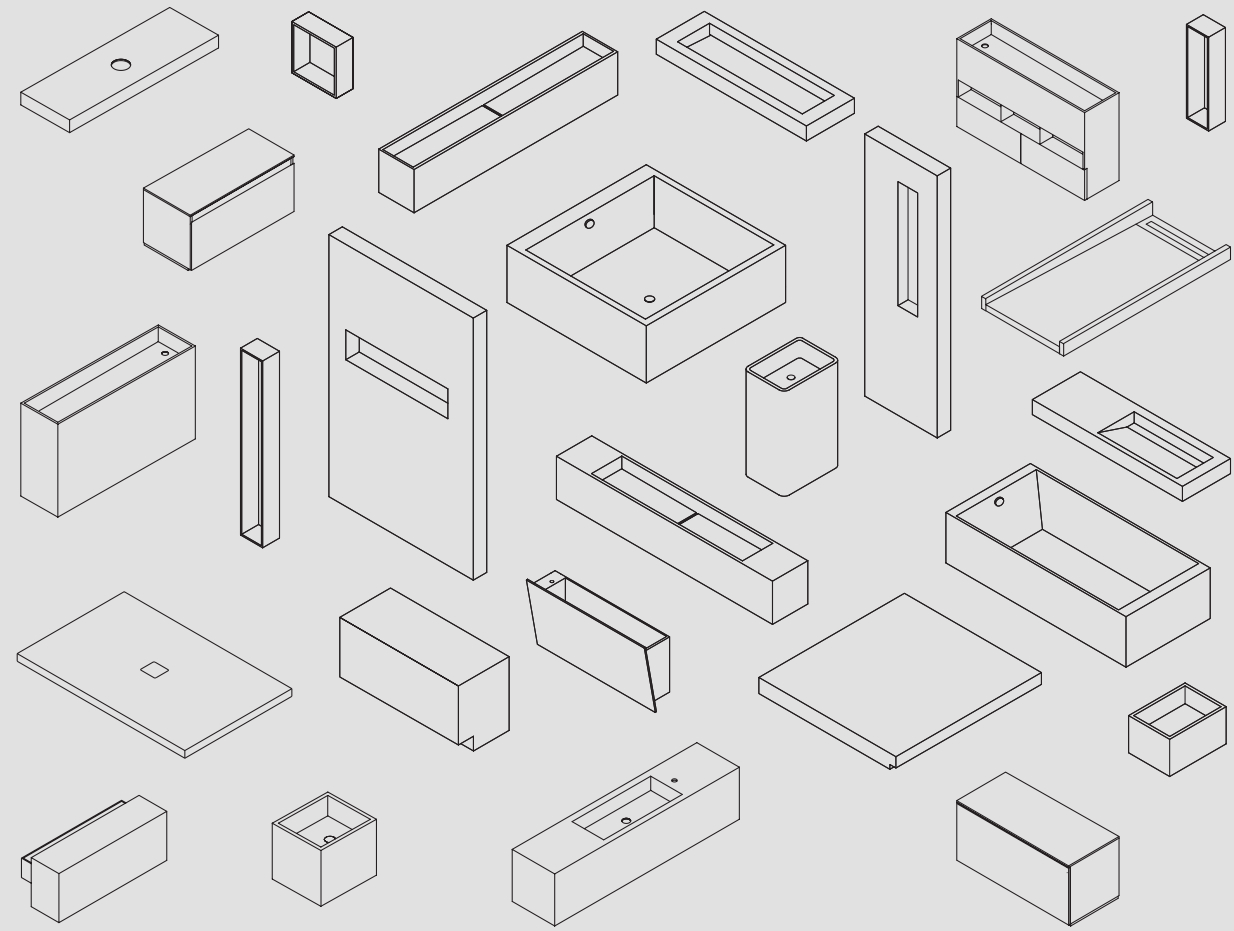

TECH INFO

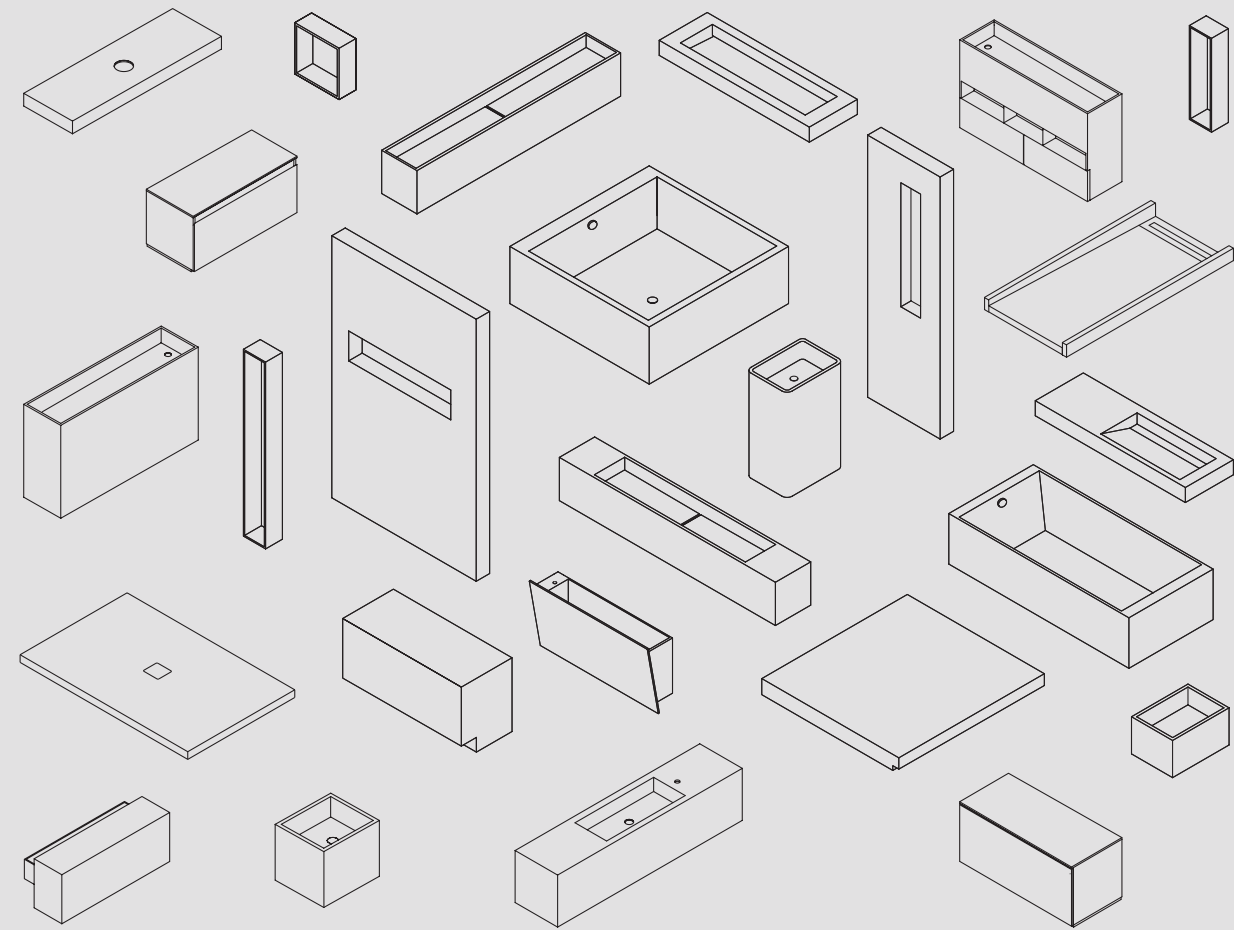
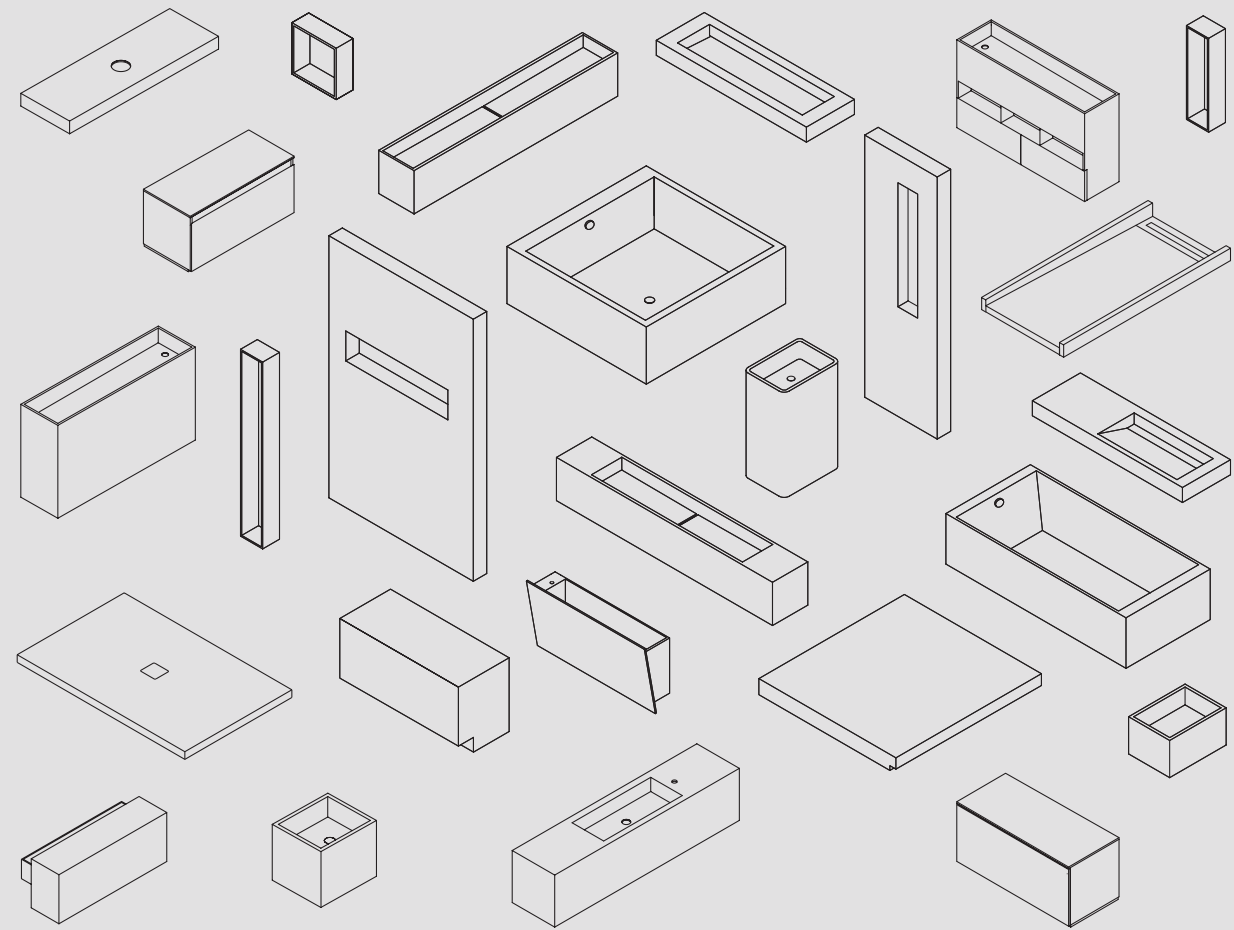

VASCHE DA BAGNO / BATHTUBS



Le vasche Line sono la quintessenza di / Elements e si distinguono per la loro unicità tecnica e costruttiva. Sono realizzate in TechnoPVC saldato e sono completamente rivestibili sia nel volume interno che esternamente. La variabilità del bordo perimetrale, l'accessoriabilità dedicata e la personalizzazione dimensionale, consentono di realizzare soluzioni di assoluto senso estetico. Risultano essere particolarmente indicate per finiture a superficie continua e per i materiali ceramici e lapidei in lastra.

Line bathtubs are the quintessence of Elements and are distinguished by their technical and constructional uniqueness. They are made of welded Technopvc and can be fully clad both inside and outside. The different thickness of the perimeter edge, the dedicated fittings and the dimensional customization lead to solutions of absolute aesthetic sense. They are particularly suitable for continuous surface finishes and for ceramic and stone slab materials.

LINE _ R

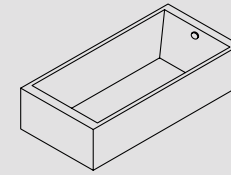

LINE _ Q

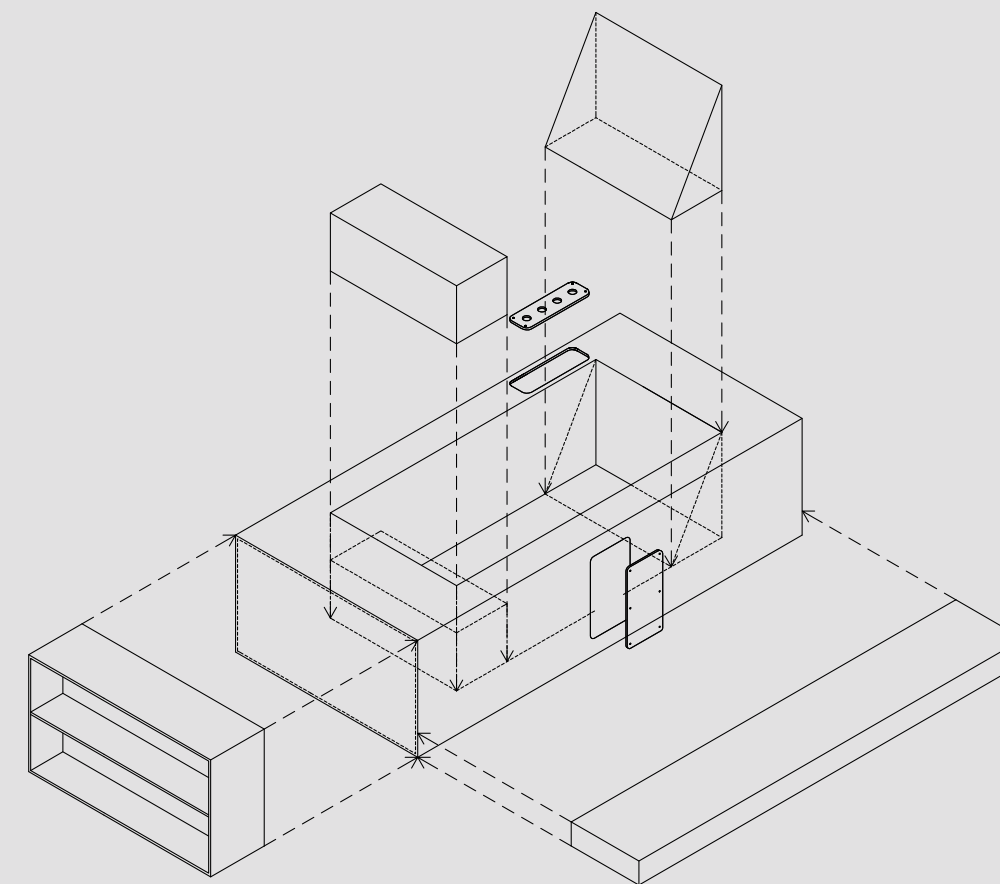
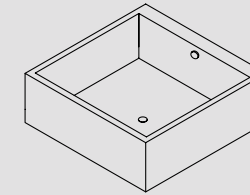

ACCESSORIABILITÀ FITTINGS

- Schienale / Backrest
- Gradino interno / Inner step
- Asola per installazione rubinetteria e colonna di scarico / Cut-out for taps and drain's installation
- Gradino interno ed esterno / Internal and external step
- Vano a giorno / Open rack

TIPOLOGIE DI SCARICO

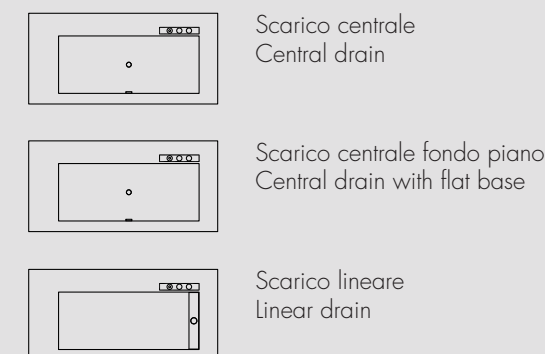

INSTALLAZIONE - INSTALLATION

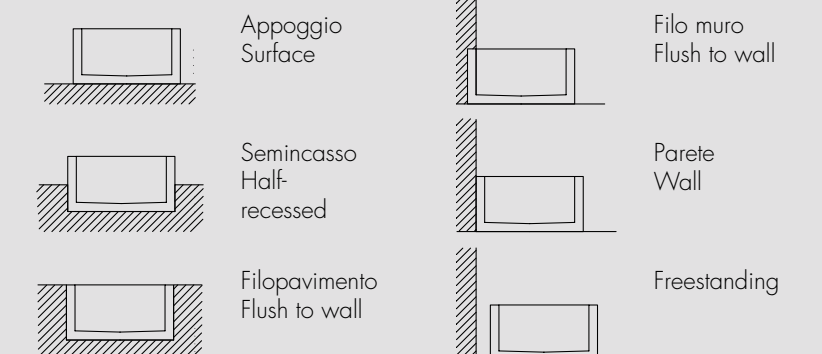



TIPOLOGIE DI SCARICO

Scarico lineare per rivestimento in gres ceramico e in marmo. Scarico centrale per rivestimento in marmo e resine-cementizie.

DRAIN TYPOLOGIES

Linear drain for tiles and marble. Central drain for marble and resins.

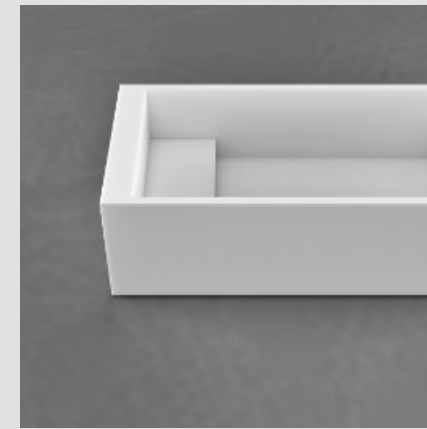

GRADINI INTERNI ED ESTERNI / INTERNAL AND EXTERNAL STEPS

La vasca è personalizzabile con gradini interni ed esterni e con ribassi integrati al bacino con funzione di seduta.

The bathtub can be equipped with internal and external steps and with lowers integrated in the base with a seating function.



ASOLA VANO TECNICO

In corrispondenza dello scarico e della rubinetteria si trova un'asola removibile ed ispezionabile.

TECHNICAL CUT-OUT

A removable cut-out allows the inspection of the drain and of the taps.

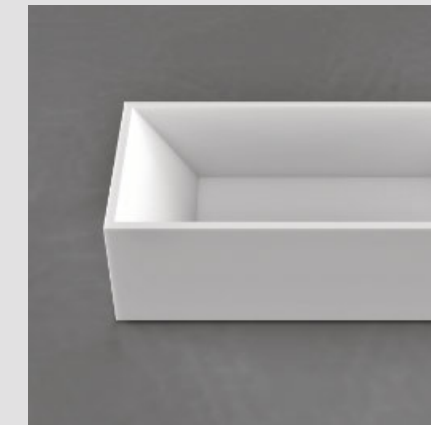

SCHIENALI

Le vasche LINE sono realizzate di serie con fianchi interni di 90°. Sono accessoribili con schienali inclinati di 25° su 1 o 2 lati e con schienali in legno.

BACKREST

The bathtubs LINE are produced with inner sides at 90°, but can be supplied also with sides sloped at 25° on one or two sides or with backrests in wood.

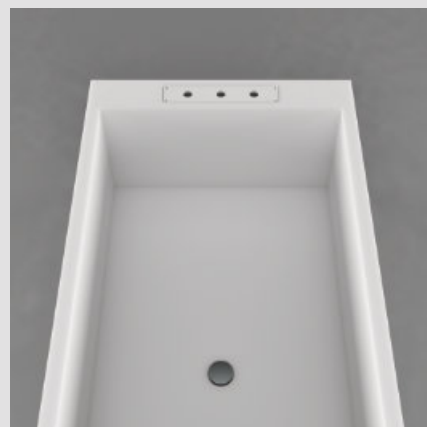



**CONTENITORI IN ACCOSTAMENTO
COMBINED STORAGE UNITS**

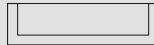

TIPOLOGIE SCHIENALI

BACKREST TYPES

-  Schienale standard 90°
Standard backrest 90°
-  Schienale singolo 25°
Single backrest 25°
-  Schienale doppio 25°
Double backrest 25°



VASCHE ASIMMETRICHE

Le vasche possono essere realizzate a misura con volumetrie simmetriche e asimmetriche.

ASYMMETRIC BATHTUB

The bathtubs can be customized and produced both symmetric and asymmetric.



VANI A GIORNO INTEGRATI

Per inserimento contenitori. Nel vano a giorno integrato in TechnoPVC è necessario inserire sempre un contenitore.

OPEN RACKS

For storage units. A storage unit needs to be included in the integrated open rack in Technopvc.

TECHNOWALL



Technowall è un setto tecnico per il bagno progettato e realizzato come soluzione alternativa alla tecnica costruttiva e ai materiali tradizionali, in grado di superare molti dei limiti prestazionali di questi ultimi. In Technowall le qualità di Impermeabilità, saldabilità e lavorabilità del TechnoPVC permettono di inserire elementi quali profili per led e per box complanari alla struttura con estrema facilità e con la consapevolezza della piena sicurezza in termini di tenuta idraulica. Un abaco ragionato di modelli disponibili dedicati alle 4 aree funzionali del bagno: lavabo, doccia, vasca e sanitari sono una soluzione pratica alle esigenze di cantiere e pone le condizioni per innovative soluzioni progettuali.

It is a technical partition for the bathroom designed and built as an alternative solution to traditional construction techniques and materials. It overcomes many of the performance limits of old materials. In Technowall the quality of watertightness, weldability and workability allow you to add elements such as LED and glass profiles flush to the structure in a very easy way and in full safety in terms of water tightness. A rational panel of models dedicated to the 4 functional areas of the bathroom: sink, shower, bathtub and sanitaryware become a practical solution to the needs of the building site and set the conditions for innovative design solutions.

TECHNOWALL LAVABO / WASHBASIN

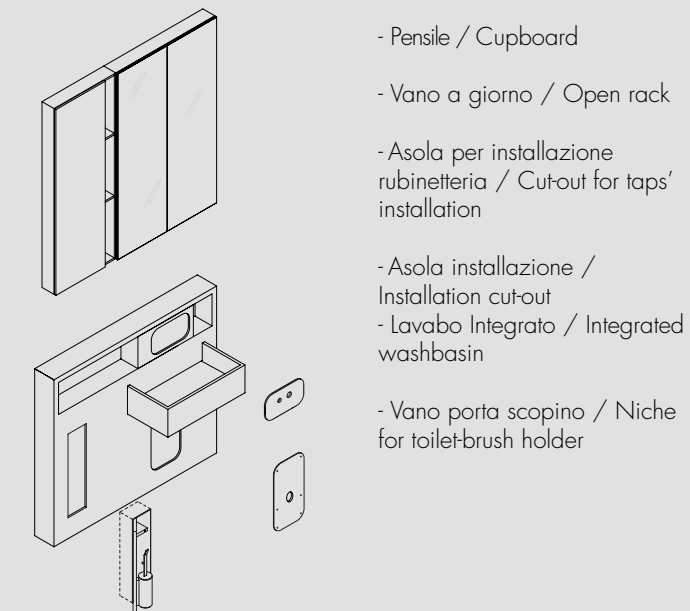

- Pensile / Cupboard
- Vano a giorno / Open rack
- Asola per installazione rubinetteria / Cut-out for taps' installation
- Asola installazione / Installation cut-out
- Lavabo Integrato / Integrated washbasin
- Vano porta scopino / Niche for toilet-brush holder

TECHNOWALL VASCA / BATHTUB

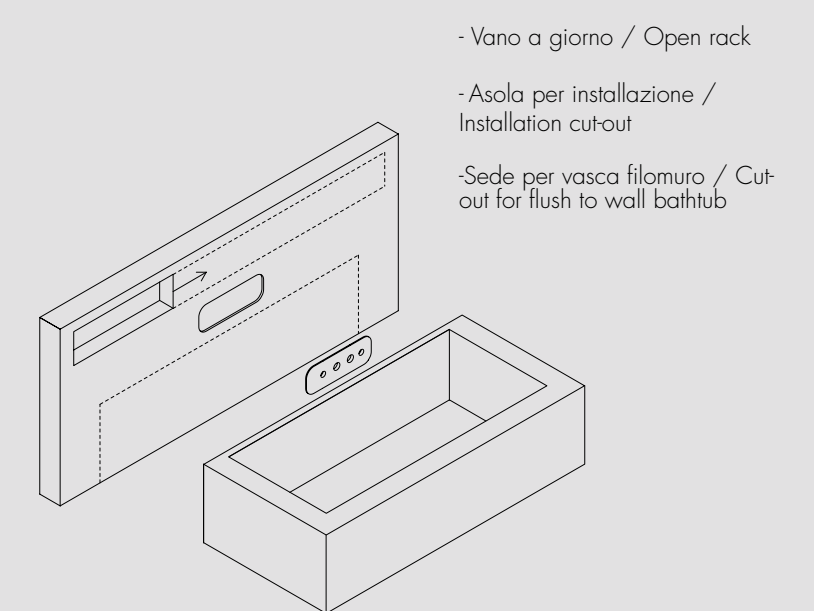

- Vano a giorno / Open rack
- Asola per installazione / Installation cut-out
- Sede per vasca filomuro / Cut-out for flush to wall bathtub

TECHNOWALL H 270 a soffitto / Full-height

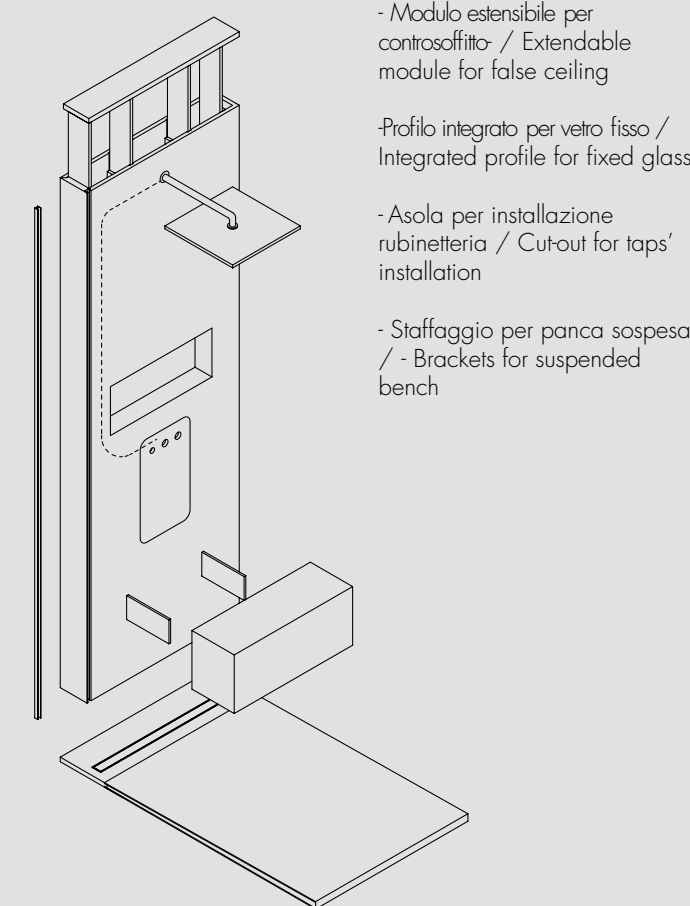

- Modulo estensibile per controsoffitto / Extendable module for false ceiling
- Profilo integrato per vetro fisso / Integrated profile for fixed glass
- Asola per installazione rubinetteria / Cut-out for taps' installation
- Staffaggio per panca sospesa / - Brackets for suspended bench

TECHNOWALL SANITARI / WC + BIDET

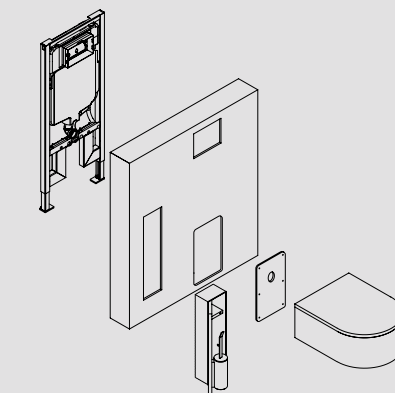

- Staffaggio per sanitario sospeso / - Brackets for suspended WC / bidet
- Asola per cassetta sanitaria e installazione / Cut-out for sanitary box
- Vano porta scopino / Niche for toilet-brush holder

TECHNOWALL H 120

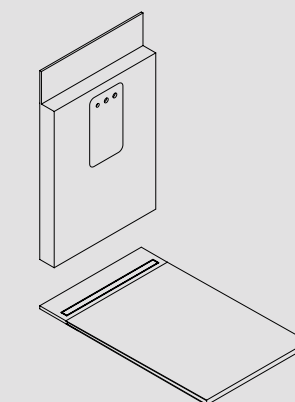

- Rialzo saldato / Welded riser
- Vano a giorno / Vano a giorno
- Asola per installazione / Cut-out for taps' installation
- Integrabile con piatti doccia / Module to integrate Technowall on the shower tray
UNICO / BASIC SHOWER LINK / INSIDE

TECHNOWALL DOCCIA / SHOWER

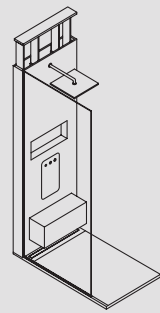

H 270 cm /
Soffitto Ceiling

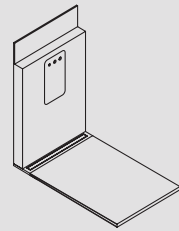

H 160 cm



ASOLA RUBINETTERIA

Asola per installazione rubinetteria e supporto per gruppo incasso.

CUT-OUT FOR TAPS

Cut-out for taps' installation and built-in parts' support.



PROFILO PER VETRO INTEGRATO

Profili in alluminio integrati a filo per inserimento vetro box.

PROFILE FOR INTEGRATED GLASS

Flush profiles in aluminum for integrated glass.



PANCA SOSPESA

Technowall accessoriabile con panca sospesa e relativo staffaggio.

SUSPENDED BENCH

Technowall can be equipped with a suspended bench with dedicated wall fixing brackets.

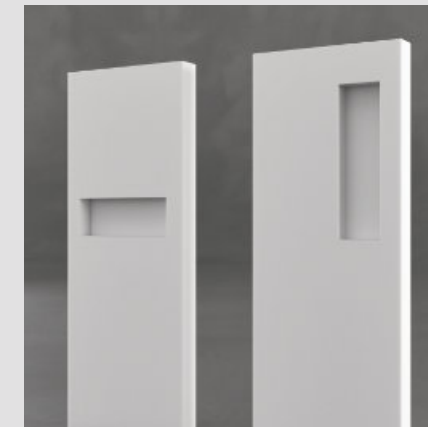

VANI A GIORNO

Vani a giorno di varie dimensioni integrabili.

OPEN RACKS

Open racks available also with LED lighting system.



PREDISPOSIZIONE SCARICO INSIDE

Predisposizione asola per piatto doccia Inside.

DRAIN FOR SHOWER TRAY INSIDE

Cut-out for shower tray Inside.



MODULO ESTENSIBILE

Modulo estensibile in Technopvc per controsoffitti in cartongesso.

EXTENDABLE MODULE

Extendable module in Technopvc for false ceilings in plasterboard.

TECHNOWALL LAVABO / WASHBASINS

LAVABI COMPATIBILI CON TECHNOWALL

Diversi tipi di lavabo in TechnoPVC possono essere applicati per accostamento o integrazione nel Technowall.

WASHBASINS SUITABLE FOR TECHNOWALL

Different types of TechnoPVC washbasins can be combined or integrated with Technowall.

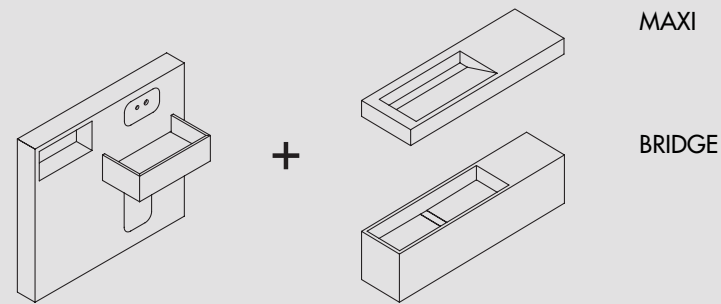

ASOLE E VANI TECNICI

Asole e vani tecnici per allacciamenti idraulici e installazione miscelatori.

CUT-OUTS AND TECHNICAL OPEN RACKS

Cut-outs and technical racks suitable for water connections and mixers' installation



LAVABO INTEGRATO

Lavabo saldato a filo del Technowall.

INTEGRATED WASHBASIN

Washbasin welded flush to Technowall.



LAVABO ACCOSTATO

Piano lavabo aderente al setto tramite staffaggio specifico.

SUSPENDED WASHBASIN

Washbasin fixed to the wall through dedicated fixing brackets.



VANI A GIORNO

Vani a giorno orizzontali e verticali integrabili in tutti i setti tecnici. Accessoriabili con led.

OPEN RACKS

Horizontal and vertical open racks can be integrated in all technical walls. They are available with LED lighting system.

TECHNOWALL SANITARI / WC+BIDET



SET PORTA SCOPINO

Integrazione set porta scopino e porta carta.

TOILET-BRUSH SET

Toilet-brush and toilet-paper holder set.

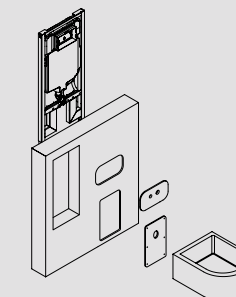

TECHNOWALL BIDET

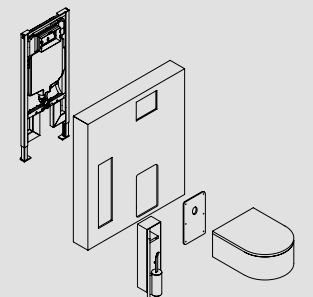

TECHNOWALL WC

TECHNOWALL VASCA / BATHTUB



Sede per vasca filomuro
Cut-out for flush to wall bathtub

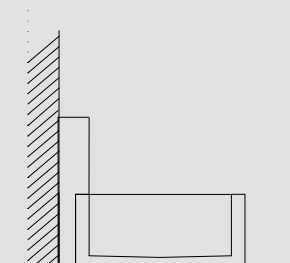
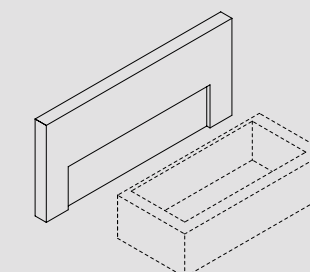

PIATTI DOCCIA / SHOWER TRAY

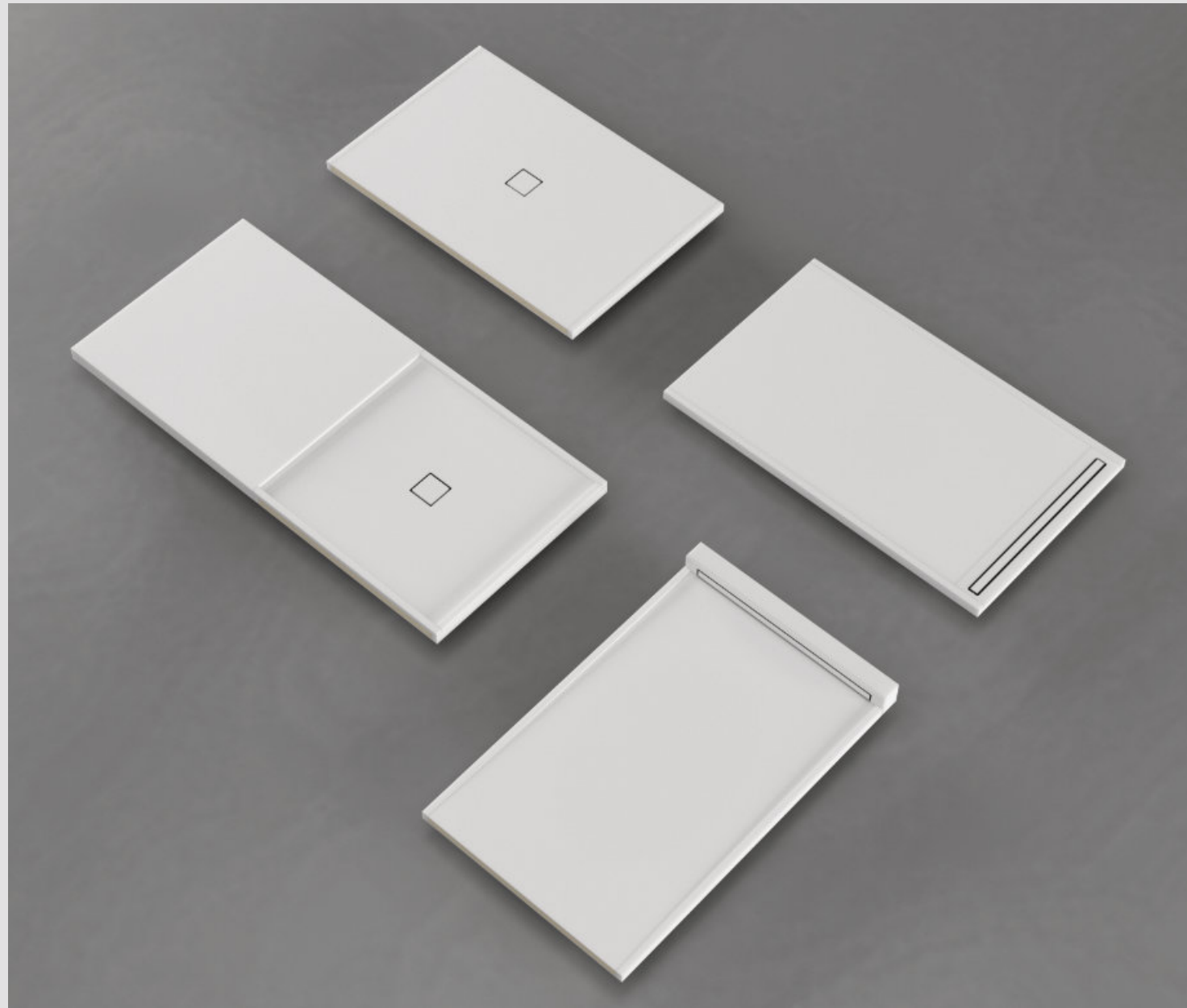

Nei piatti doccia in TechnoPVC trovano massimo risalto le principali caratteristiche dei prodotti / Elements: innovazione, soluzioni tecniche avanzate, progettualità, flessibilità produttiva, sicurezza idraulica e praticità di installazione. Il programma comprende piatti doccia con scarico lineare integrato Unico, con scarico centrale Basic Shower e il nuovo scarico lineare a parete Inside. Sono prodotti con dimensioni fino a 300x200 cm con pileta singola o doppia, in diverse soluzioni combinatorie e installabili sia a filo pavimento che in appoggio. Link è un modello di piatto in appoggio con scarico centrale e bacino integrato in un piano di contenimento.

The main characteristics of Elements products express at their best in the TechnoPVC shower trays: innovation, advanced technical solutions, design, production flexibility, water tightness and easy installation. The program includes the shower tray Unico with integrated linear drain, Basic Shower with central drain and the new Inside with linear drain on the wall. They are produced with dimensions up to 300x200 cm with single or double drain, in different combinations and they can be installed both floor flush and floorstanding. Link is a floorstanding model with central drain and basin integrated into a step.

PIATTI DOCCIA / SHOWER TRAY

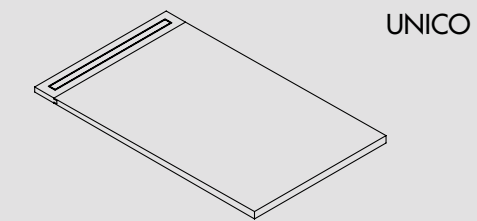

UNICO

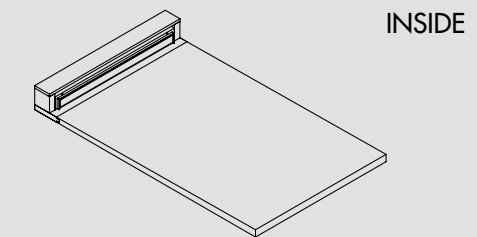

INSIDE

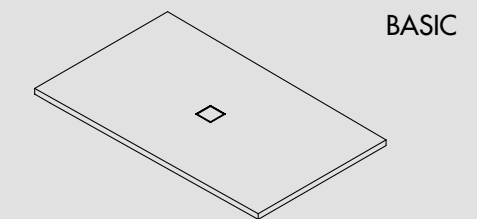

BASIC

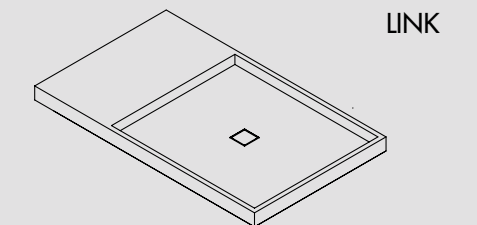

LINK

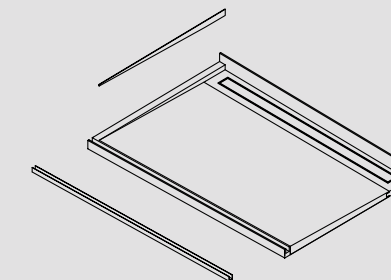

ACCESSORIABILITÀ FITTINGS

- Profilo pendenza / Sloped profile
- Rialzo pre-saldato lato contro muro / Pre-welded riser on the wall side
- Bordo filozero aggiuntivo pre-saldato / Pre-welded flush-riser
- Profilo per vetro integrato / Profile for integrated glass
- Asola per installazione rubinetteria / Cut-out for taps' installation
- Asola installazione / Installation cut-out
- Lavabo Integrato / Integrated washbasin
- Vano porta scopino / Toilet-brush holder niche

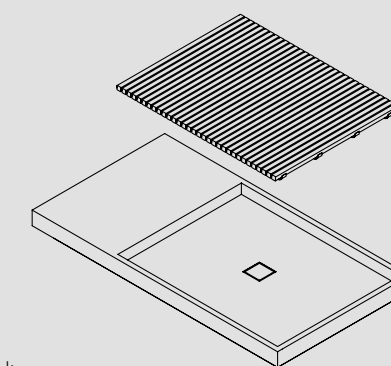
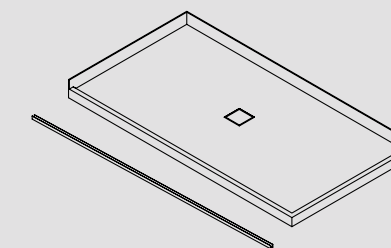
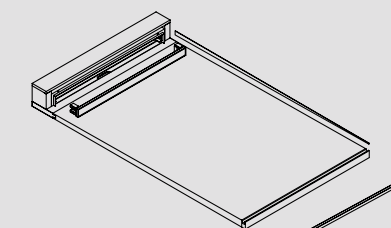

Modi di installazione / Additional processing

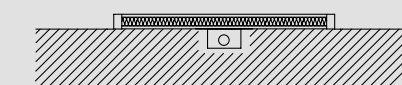

Appoggio / Floorstanding



Filopavimento / Floorflush



Filopavimento ribassato
Floorflush recessed



UNICO

Piatto doccia con scarico lineare integrato per installazioni a filo pavimento e in appoggio.

Shower tray with integrated linear drain suitable for floor flush and floorstanding installation.

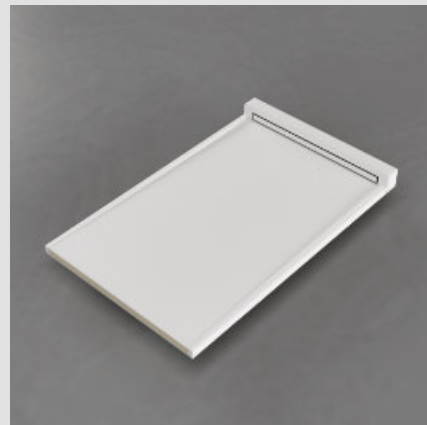

INSIDE

Piatto doccia con scarico lineare a parete integrato per installazioni a filopavimento.

Shower tray with integrated wall linear drain suitable for floor flush and floorstanding installation.



BASIC

Piatto doccia con scarico centrale per installazioni a filopavimento e in appoggio.

Shower tray with central drain suitable for floor flush and floorstanding installation.



LINK

Piatto doccia con scarico centrale e pedane laterali integrate per soluzioni simmetriche e asimmetriche. Installazione in appoggio.

Shower tray with central drain and integrated lateral steps leading to symmetric and asymmetric solutions Floorstanding installation.

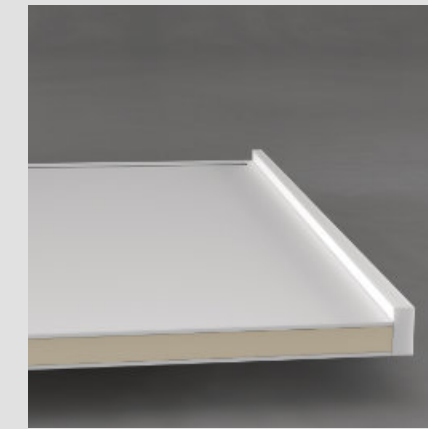

BORDO ZERO A / EDGE TYPE "A"

Bordo in TechnoPVC presaldato al piatto, spessore 30 mm. / 30 mm TechnoPVC edge welded to the plate

BORDO ALTO B / EDGE TYPE "B"

bordo in TechnoPVC, presaldato al piatto, spessore 30 mm. / Higher 30 mm edge type "B" in Technopvc welded to the shower tray.

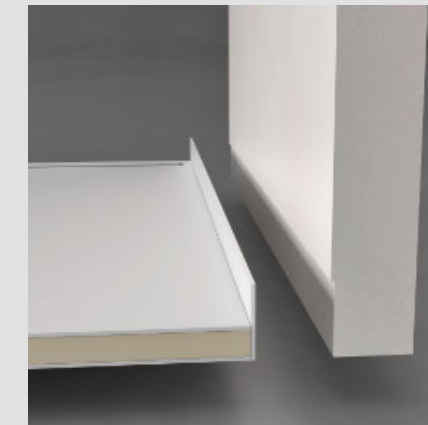

PROFILO INTEGRATO per box doccia: in presenza di Bordo A - B è possibile integrare profili dedicati per box doccia.

INTEGRATED PROFILE for shower screen: profiles for the shower screen can be integrated in edges type A - B.

RIALZO LATI CONTROMURO: rialzo in TechnoPVC presaldato al piatto, spessore 6 mm (lati a muro).

RISERS AGAINST THE WALL: risers in TechnoPVC welded to the shower tray 6 mm thick (wall sides).



PROLUNGHE PER PANCA: Prolungamento in TechnoPVC lato canalina per integrazione panca a terra.

BENCH EXTENSIONS: Extensions in TechnoPVC on the drain side to integrate floorstanding benches

PROLUNGAMENTO in technopvc per integrazione con technowall.

EXTENSIONS in technopvc to integrate technowall.

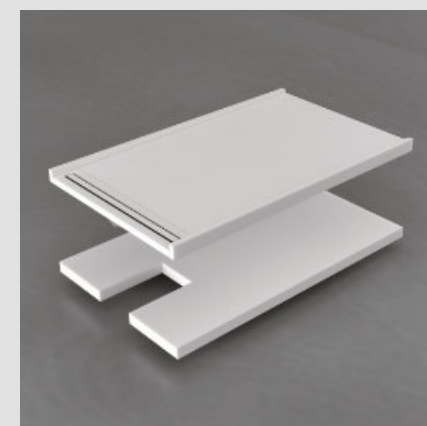

SUPPORTO DI RIALZO EPS

Supporto in EPS per soluzioni fuori terra o particolari.

RISER IN EPS

Riser in EPS for floorstanding or bespoke solutions.

AREA LAVABO / WASHBASIN AREA

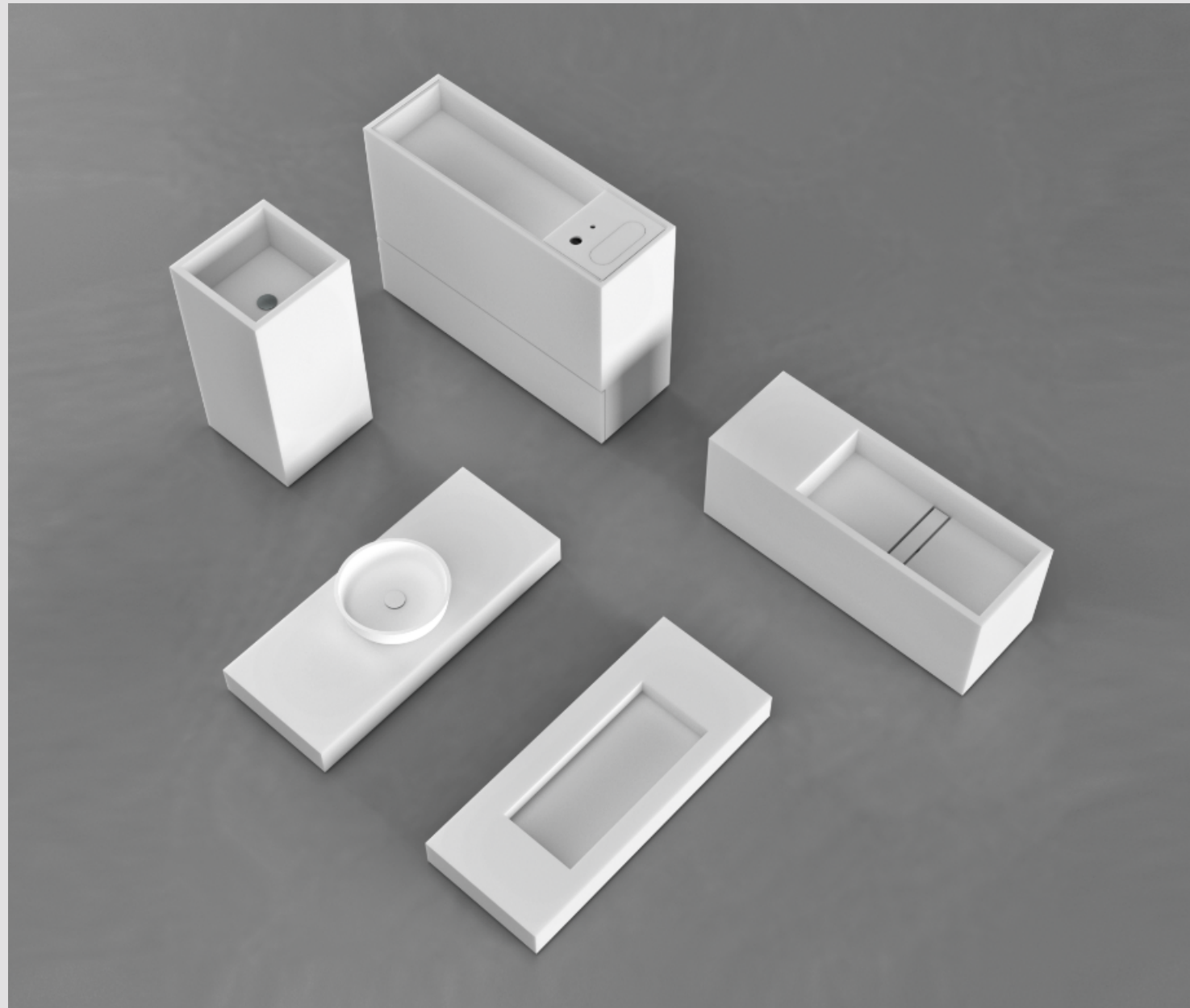

L'area lavabo è composta da un vario abaco di prodotti in TechnoPVC e offre molteplici soluzioni tipologiche di lavabi freestanding e piani sospesi e da terra con lavabo integrato. Tali prodotti sono abbinati ai relativi contenitori organizzati per modelli, dimensioni e finiture. Si creano così composizioni semplici o complesse, di grande rilievo e dettaglio.

The washbasin area consists of a wide range of TechnoPVC products and offers several typological solutions of freestanding washbasins and suspended and floor-standing consoles with integrated washbasins. These products are combined with the dedicated containers, organized by model, size and finish, leading to simple or complex compositions of great prominence and detail.

LAVABI / WASHBASINS

MAXI

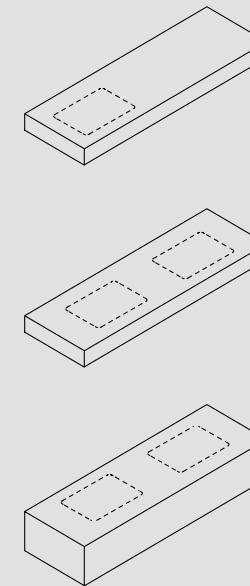

BRIDGE

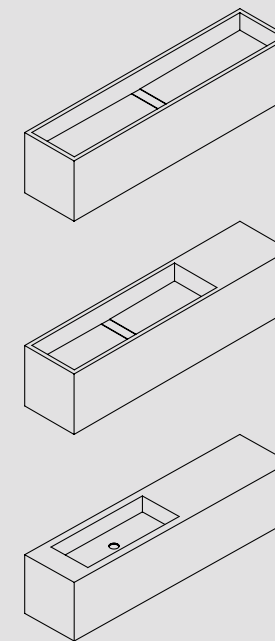

MODULO T

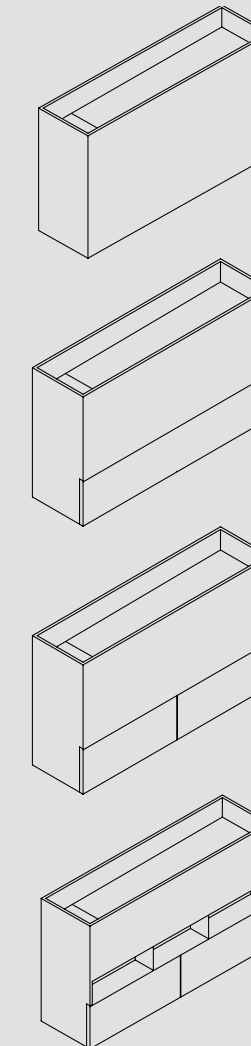

SLASH

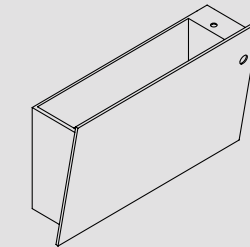

PURO

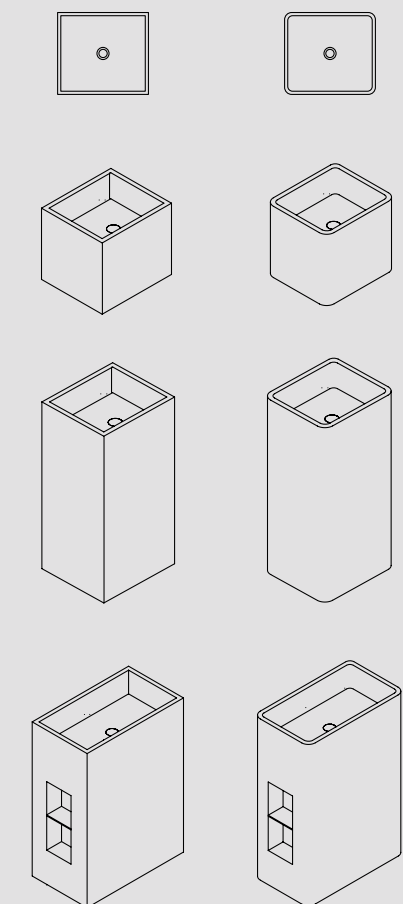

LAVABO / WASHBASIN MAXI

Il programma Maxi comprende lavabi integrati sospesi, disponibili in tre versioni a seconda della profondità, del tipo di piano e di scarico. Realizzabili su misura e accessoriabili con contenitori di diverse altezze e dimensioni.

The Maxi programme includes integrated wall-hung washbasins, available in three versions according to depth, model and drain. They can be made to measure and can be equipped with storage units of different heights and sizes.

L Max 300 cm
P 48 / 55 cm
H 13 cm

Lavabo / Washbasin
50X30 (P. 48-55) cm
70X32 (P. 48-55) cm
90X39 (P. 55) cm

MAXI CON LAVABO SINGOLO INTEGRATO
H 13 cm

MAXI WITH SINGLE INTEGRATED WASHBASIN
H 13 cm

Altezza variabile a richiesta.
Variable height on request

<< MAXI CON LAVABO CONTINUO
MAXI WITH FULL-LENGTH WASHBASIN

< MAXI CON DOPPIO LAVABO
MAXI WITH DOUBLE WASHBASIN

MAXI CON LAVABO IN APPOGGIO
MAXI WITH SURFACE WASHBASIN

Lavabi in appoggio - Semincasso
Surface - half recessed washbasins

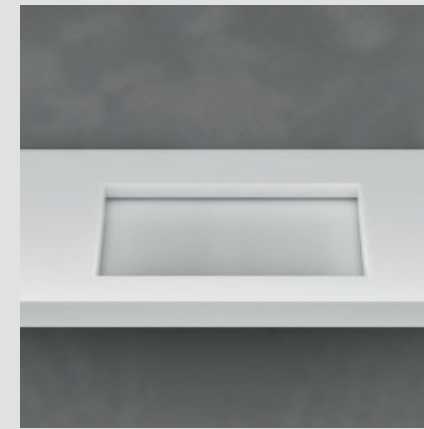
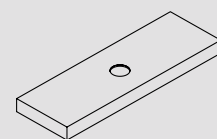
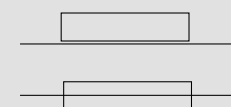

SLI SCARICO LINEARE INTERNO

SLI INNER LINEAR DRAIN

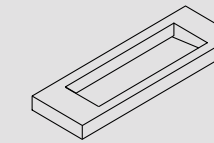
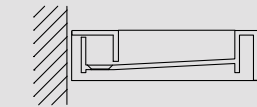

SLE SCARICO LINEARE ESTERNO SLE
EXTERNAL LINEAR DRAIN

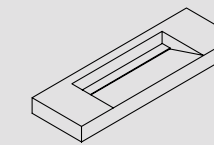
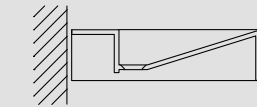

SC SCARICO LINEARE CENTRALE SC
CENTRAL LINEAR DRAIN

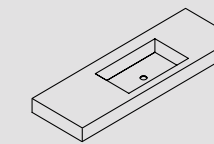
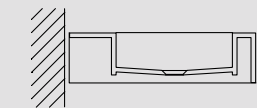

LAVABO / WASHBASIN BRIDGE



Elemento solido e compatto ma, allo stesso tempo, snello e leggero. Disponibile in due altezze e con scarico lineare o centrale.

Solid and compact unit, which is at the same time slender and light. It's available in two heights and with linear or central drain.

L Max 300 cm
P 42,5 cm
H 35 / 45 cm

Lavabo / Washbasin
50X30 cm
70X30 cm
90X30 cm
120X30 cm

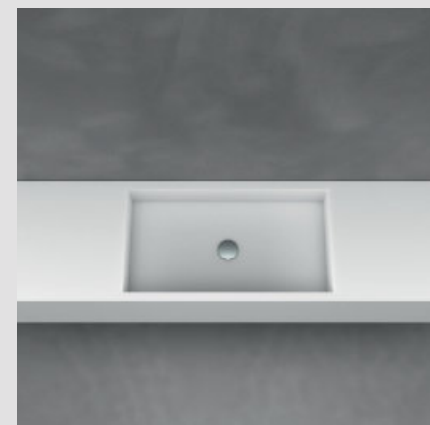
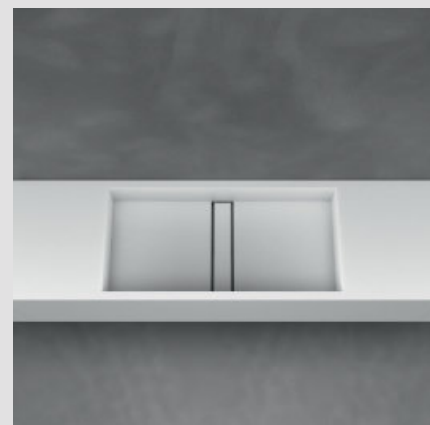
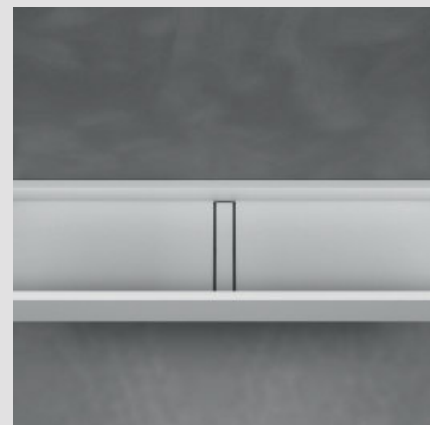
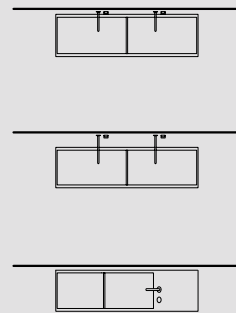

LAVABO / WASHBASIN PURO



Lavabi sospesi o freestanding con bordo perimetrale a tutto spessore caratterizzato da raccordi angolari retti o stondati. In versione sospesa è completo di staffa di fissaggio a muro.

Suspended or freestanding washbasin with thick square or round perimeter edges. In the suspended version it is supplied with wall fixing brackets.

L 45 / 65 cm
P 40 cm
H 40 / 90 cm

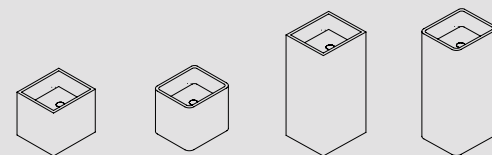

LAVABO / WASHBASIN MODULO T



Blocco lavabo da terra in TechnoPVC, freestanding o a parete, internamente rivestibile. È possibile abbinare lavabi di materiali diversi. Accessoriabile con cassetti e vani a giorno.

Floorstanding monoblock in TechnoPVC, freestanding or wall hung, which can be clad also inside and which can be equipped with drawers and open racks. It's possible to combine washbasins of different materials.

L Max 200 cm
P 42,5 cm
H 35 / 90 cm

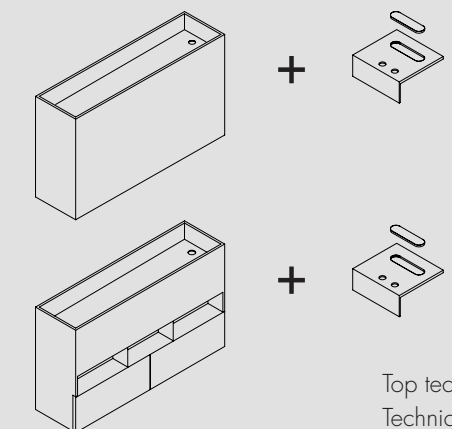

Top tecnico
Technical top

LAVABO / WASHBASIN SLASH

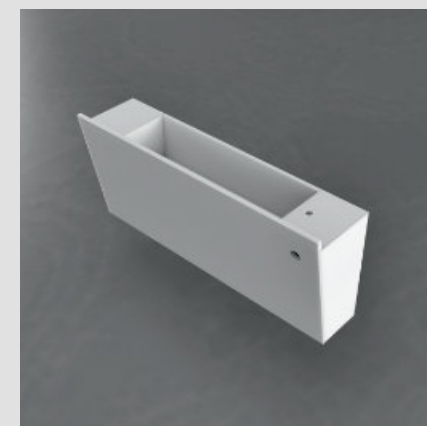

Lavabo lineare a sezione rastremata e con profondità ridotta. Personalizzabile con miscelatore e bocca di erogazione integrati

Linear washbasin with tapered section and reduced depth, which can be customized with integrated mixer and spout.

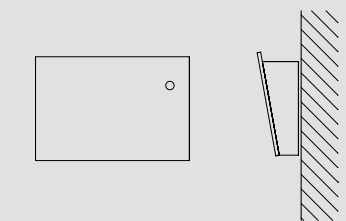

BRIDGE + CABINET

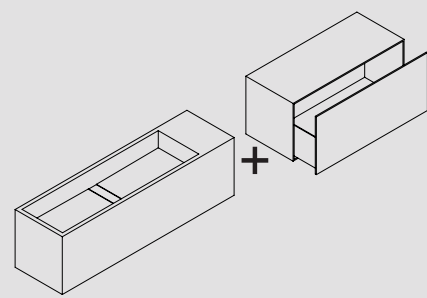

Bridge contenitori accostati
Linear waste washbasin mod. 01

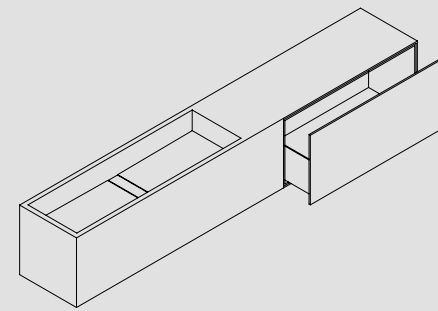

Bridge contenitori integrati
Linear waste washbasin mod. 01

Mobili contenitori con cassetto da affiancare o integrare ai lavabi Bridge, con altezza 35 e 45 cm e profondità 42,5 cm. La serie integrata è rivestibile esternamente con resine, cementi e gres.

Storage units to be combined or integrated with the Bridge consoles, available in heights 35 and 45 cm and depth 42,5 cm. The integrated series can be clad on the outside with resins, cements and tiles.

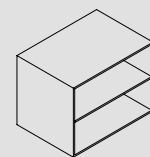

Vano a giorno
Open rack
H 35-45 cm
L 40-60-80-100 cm
P = 42,5 cm

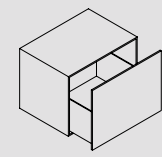

Cassetto singolo
Single Drawer
H 35-45 cm
L 40-60-80-100-120 cm
P = 42,5 cm

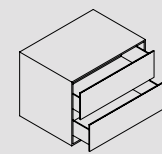

Cassetto doppio
Double Drawer
H 35-45 cm
L 40-60-80-100-120 cm
P = 42,5 cm

MAXI + CABINET

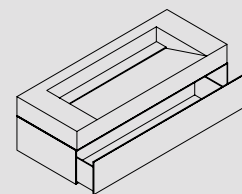

Base Cassetto
Drawer
H 25 cm
L 40-60-80-100-120 cm
P = 48 / 55 cm

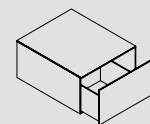

Cassetto singolo
Single Drawer
H 40 cm
L 40-60-80-100-120 cm
P = 48 / 55 cm

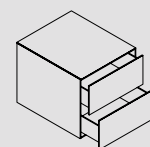

Cassetto doppio
Double Drawer
H 40 cm
L 40-60-80-100-120 cm
P = 48 / 55 cm

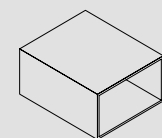

Vano a giorno
Open rack
H 25 cm
L 40-60-80-100-120 cm
P = 48 / 55 cm

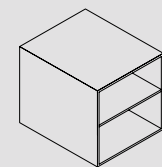

Vano a giorno H 40 cm
Open rack
H 25 cm
L 40-60-80-100-120 cm
P = 48 / 55 cm

Programma di mobili sottopiano coordinati ai piani lavabo Maxi, con cassetti singoli o doppi, realizzati in altezza 25 e 40 cm

Programme of cabinets matching with the consoles Maxi and equipped with double or single drawers having height 25 and 40 cm.

PUNTO.0

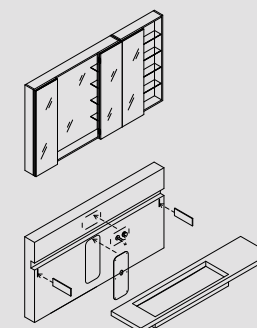

Punto.zero è una parete attrezzata a filomuro con lavabo integrato, per soluzioni spaziali ricercate ed essenziali. Il particolare e raffinato sistema di apertura delle ante a 180° consente di celare un sistema di contenitori e specchi sorprendente e di grande dinamicità, a servizio della persona. Ma è soprattutto da chiuso che emerge la qualità estetica delle diverse soluzioni grazie alla coplanarità con la parete di fondo e all'espressività del piano lavabo.

Punto.zero is a flush technical wall with integrated washbasin for sophisticated and essential spatial solutions. The unique and refined system of 180° door opening conceals a surprising and highly dynamic system of storage units and mirrors. Especially when closed the aesthetic quality of the several solutions stands out thanks to the coplanarity with the back wall and the expressivity of the washbasin top.

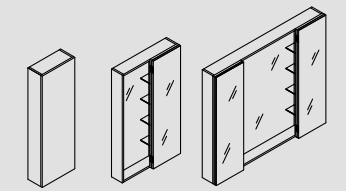

L 40-80-160 cm
P 20 cm
H 80-100-120 cm

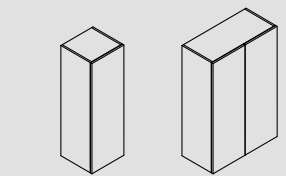

L 40-80 cm
P 35 cm
H 120 cm

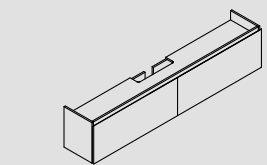

L 80-120-160-200 cm
P 40 cm
H 50 cm

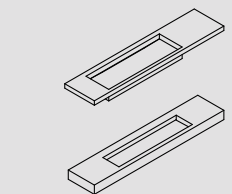

L Max 200 cm
P 40 cm
H 6-13 cm

GRAPHIC / DOMINO

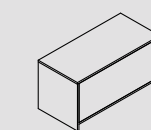

GRAPHIC

H 50 cm
L 60-80-100-120-140 cm
P 48-55 cm

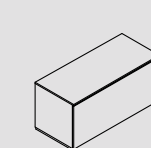
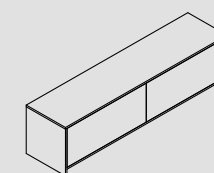

DOMINO

H 50 cm
L 60-80-100-120 cm
P 48-55

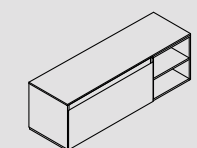
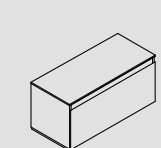
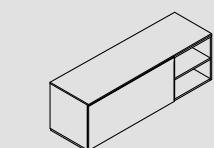

Mobili da rivestire (Domino) o in essenza / laccato (Graphic) per composizioni lineari, integrabili con l'intera gamma di vasche, docce e lavabi.

Floorstanding cabinets to be clad (Domino) or in wood / lacquered wood (Graphic) for linear compositions, which can be combined with the entire range of bathtubs, shower trays and washbasins.

COMPLEMENTI / FITTINGS



SEDUTE

Panche sospese e a terra accessoriabili con led.

BENCHES

Suspended and floorstanding benches which can be equipped with LED lighting system.

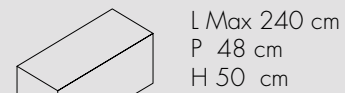

L Max 240 cm
P 48 cm
H 50 cm

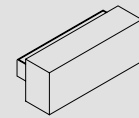

L Max 80 cm
P 25 cm
H 30 cm

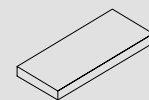

L Max 100 cm
P 40 cm
H 5.5 cm



RIALZI E PEDANE

Elementi rettangolari o quadrati accessoriabili con led. Rectangular or square open racks which can be equipped with LED lighting system.

RISERS AND FOOTBOARDS

Moduli multi-funzionali da abbinare a docce e vasche accessoriabili con led. Multifunctional modules which can be integrated to showers and bathtubs and which can be equipped with LED lighting system.

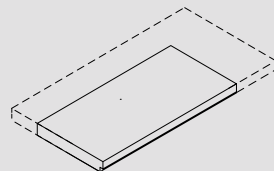

L Max 300 cm
P Max 200 cm
H 12 cm



SEDUTE

Panche sospese e a terra accessoriabili con led.

BENCHES

Suspended and floorstanding benches which can be equipped with LED lighting system.

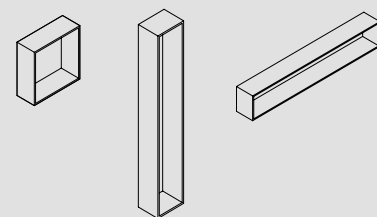

L Max 300 cm
P Min 12 cm
H Max 30 cm



BARCODE

Collezione di contenitori verticali componibili sia in verticale che orizzontale, con elementi a giorno ed ante a spessore normale e ultralight a spessore ridotto. Realizzati in doppia profondità di 20 e 35, cm, hanno larghezza di 20, 40 e 60 cm e altezze 90/120/150/180/210/240. Sono disponibili in diverse finiture.

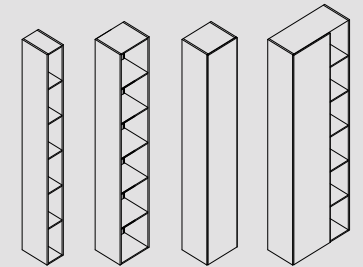

Collection of modular vertical and horizontal storage units, with open racks and normal and ultralight doors with reduced thickness. Available in depth 20 and 35 cm, width 20, 40 and 60 cm, heights 90/120/150/180/210/240 cm and in several finishes..

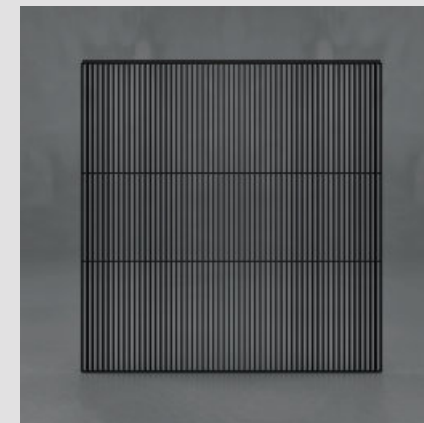

TRAMA

Elemento in alluminio anodizzato con funzione filtrante e divisoria. Disponibile in moduli fino a cm 120 x cm 270 H.

Anodized aluminum element with filtering and dividing function. Available in modules up to 120 cm x 270 cm H.

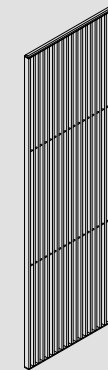

SKY MODULO CONTROSOFFITTO

Elemento strutturale per controsoffitti in cartongesso pensato per unire estetica e funzionalità e facilitare l'installazione del sistema doccia. Accessoriabile con soffioni complanari retroilluminati, profili per vetri a tutt'altezza e LED.

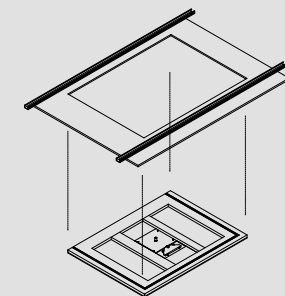

SKY MODULES FOR FALS CEILINGS

Structural elements for false ceilings in plasterboard with the aim of combining design and function and ease the installation of the shower system. They can be equipped with shower heads, also with lighting system, full-height glass profiles and profiles for the LED lighting system.

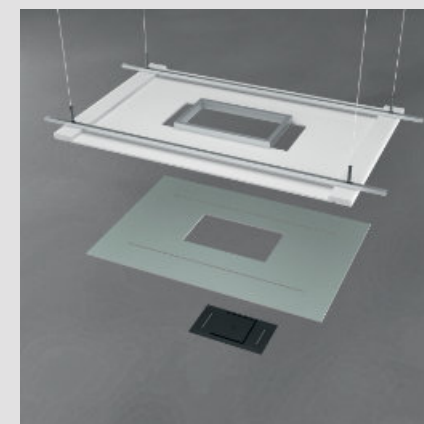

NOTE

MAKRO
bathroomconcepts

Via 1° Maggio, n.15
35030 - Bastia di Rovolon PD - Italia
Tel.: +39 049 9910951
Fax: +39 049 9910976
info@makro.it / www.makro.it

CREDITS

-
MAKRO bathroom concepts - ELEMENTS_ 2022
Art direction: Studio Marco Taietta + Makrodesign
Graphic design: Studio Marco Taietta
Photo real vision design: Francesca Fani Studio + SMT
Text: MKTG Makro.
Color separation: GM Studio1.
Printed in Italy by: G&G - printing solutions
Edition: June 2022

RISERVA

-
Makro si riserva di apportare, senza preavviso, modifiche nei materiali, nelle finiture e nei disegni presentati in questo catalogo. Le texture, i colori dei materiali e le finiture hanno valore indicativo in quanto soggetti alle tolleranze dei processi di stampa.

-
Makro reserves the right to change, without prior notice, materials, covers, finishes and drawings of the products presented in this catalogue. The textures and colors of materials and finishes are to be considered approximate as they depend on the tolerances of the printing process.

MADE IN ITALY

-
Ogni prodotto è pensato, progettato e realizzato in Italia.
-
Every product is conceived, engineered and manufactured in Italy.



MAKRO
bathroomconcepts